

Surgical Manual

122 Taper KIT

(122 Taper Full KIT)

Introduction

Welcome,

and thank you for choosing Osstem Implant products. This catalogue is designed to support dental professionals with product information, clinical workflows, and practical guidance for daily use. It is important to inform patients about the option of dental implant treatment and the potential benefits it may provide. For further information, please contact your local Osstem representative.

Important Notice

This document is provided for **informational and educational purposes only** and does not replace the applicable product label, the current product-specific Instructions for Use (IFU), formal clinical training, or independent professional judgment. All product information, specifications, and protocols are subject to change without notice. Not all products may be approved, cleared, released, licensed, or available in all markets. Product illustrations are not shown to scale. Despite careful preparation of this catalogue, typographical, editorial, translation, or printing errors may occur. **All critical information must be verified against the current product-specific IFU and product label before use.**

Electronic IFU (per (EU) 2021/2226)

- Surgical Drill & KIT System is eligible for provision of electronic instructions for use (e-IFU) under Regulation (EU) 2021/2226 for professional users.
- e-IFUs are available at [website URL: ifu.osstem.com] in the official languages required by the Member State(s) where the device is placed on the market.
- The e-IFU content is consistent with the paper version; all updates are promptly reflected in both versions.
- If requested, a paper copy of the IFU will be supplied free of charge, within 7 calendar days.
- The e-IFU website maintains historical versions for traceability of all previously applicable instructions.
- Labeling on the product/package indicates the provision of e-IFU and how to access it online.

Surgical Manual | English Edition

Publication date: April 2026

Publisher: Osstem Europe s.r.o.
Radlická 740/113c
158 00 Prague, Czech Republic

Note: *This brochure is based on the global 2021 Osstem Surgical Manual and has been visually revised and adapted for the European market. Product availability and specifications may vary by country and are subject to change without notice. Images are for illustrative purposes only. For professional use only.*

122 Taper KIT

(122 Taper Full KIT)

Surgery KIT featuring taper drills that enables placement of taper implants with maximum two drillings

Concept A Taper drill optimized for taper implant placement

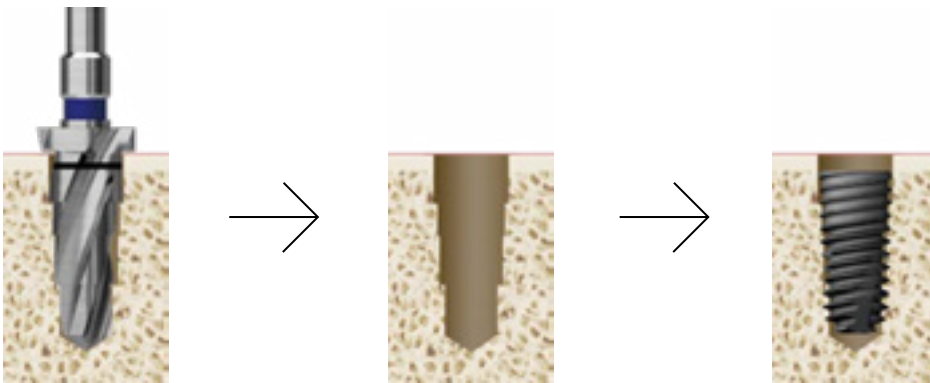

Create taper drill hole

Place taper implant

Concept B Simple and easy procedure that can be completed with just 2 drillings

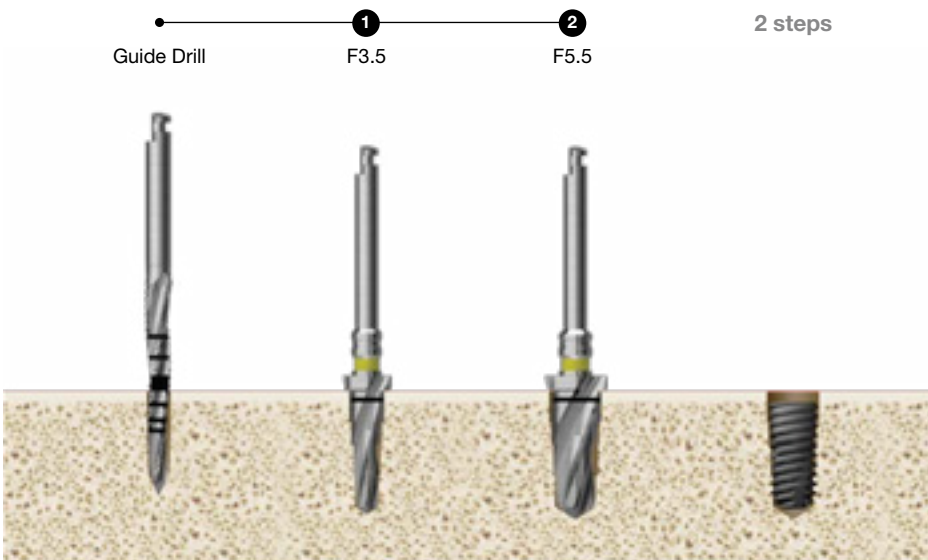

1 Indication

A When placing taper implants

- Use KIT for placing TSIII/IV, KSIII, SSIII, USIII/IV implants
- Diameter: Ø3.0, Ø3.5, Ø4.0, Ø4.5, Ø5.0, Ø5.5



B When placing ultra-wide taper implants

- Use KIT for placing TSIII/IV, KSIII, SSIII, USIII ultra-wide implants (use 122 Taper Full KIT)
- Diameter: Ø6.0, Ø7.0



2 Feature

A Maintains stable placement torque in various bone qualities

- By using various drills as final drill depending on the bone quality, interference between the implant and the bone can be adjusted to obtain the desired placement torque.
- Nominal drill: Final drill used in normal bone for each implant diameter

* Final drill for each implant diameter

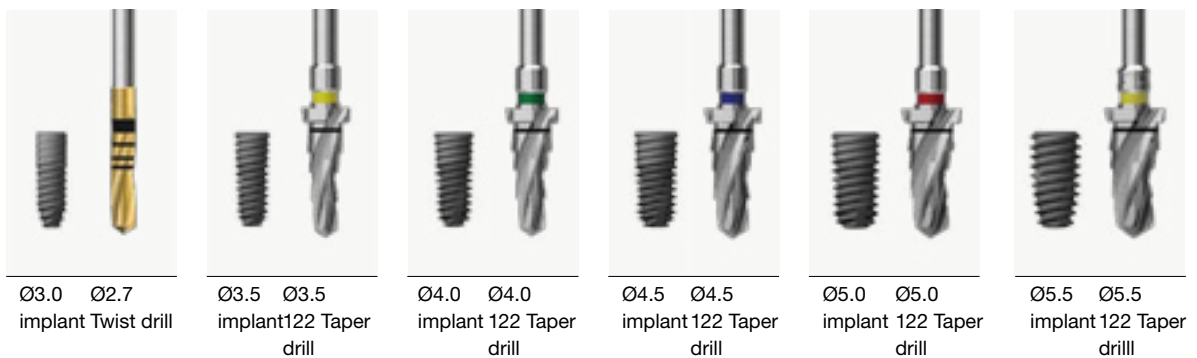

Normal bone Normal bone quality

Use nominal drill to form a drill hole that matches the diameter of the implant to be placed.

*** Example : Ø4.5×10mm placement**

After forming a drill hole with an F4.5 diameter drill, place a Ø4.5 diameter implant

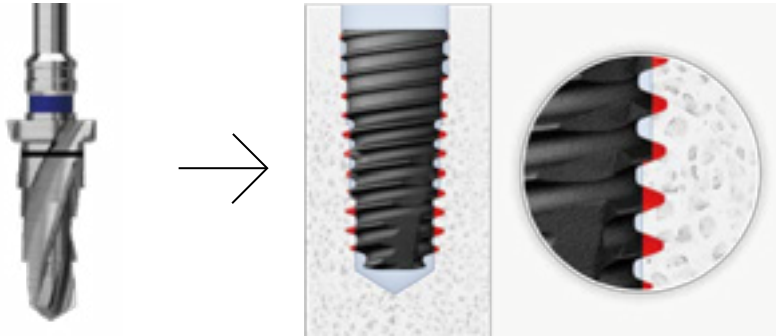

Final drill: F4.5 × 10mm

Ø4.5×10mm implant placement

Soft bone Since the bone quality is soft, bone interference must be increased to secure enough primary stability.

Create a drill hole smaller than the diameter of the implant to be placed with a drill one size smaller than the nominal drill.

*** Ø4.5×10mm placement example**

After forming a drill hole with an F4.0 diameter drill, place a Ø4.5 diameter implant

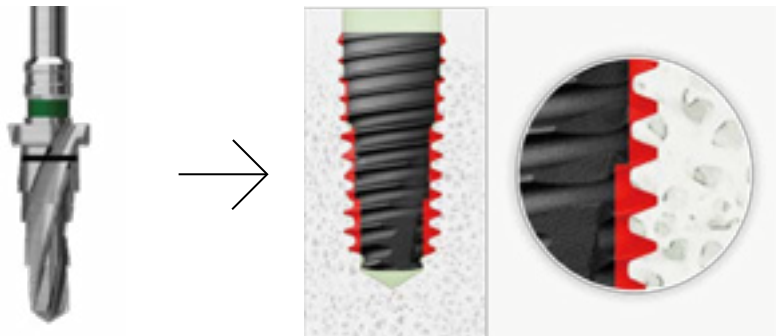

Final drill: F4.0 × 10mm

Ø4.5×10mm implant placement

Hard bone Since bone quality is hard, bone interference must be reduced to prevent over-torque and osteonecrosis.

Create a drill hole larger than the diameter of the implant to be placed with a drill one specification larger than the nominal drill.

*** Example : Ø4.5×10mm placement**

After forming a drill hole with an F5.0 diameter drill, place a Ø4.5 diameter implant

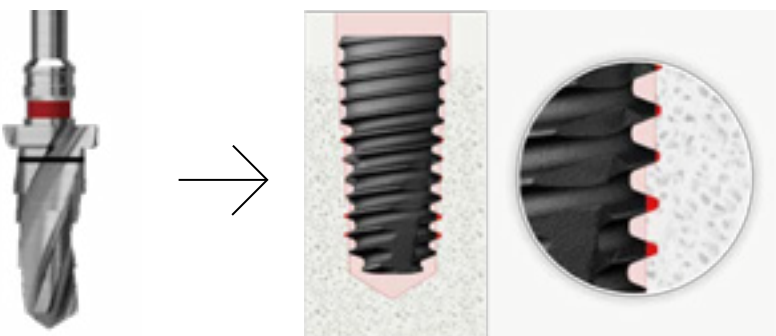

Final drill: F5.0 × 10mm

Ø4.5×10mm implant placement

B Easy to adjust drilling depth with the stopper

- Stopper is located 1mm above the indicated drill length. In case TS implant is placed, you can place the implant 1mm below bone level by having full drilling till the stopper line.
- Possible to control implant placement depth by taking the irregular bone height into account.
- When placement torque is low, the implant can be placed deeper to increase placement torque
- There is a difference between the length marked on the drill and the actual drill length: Drill is actually 1.7~2mm longer due to the Y-dim (different for each diameter, 0.7~1mm) and the 1mm margin between the laser marking line and Stopper.

* F4.5× 10mm 122 taper drill and 10mm implant length comparison

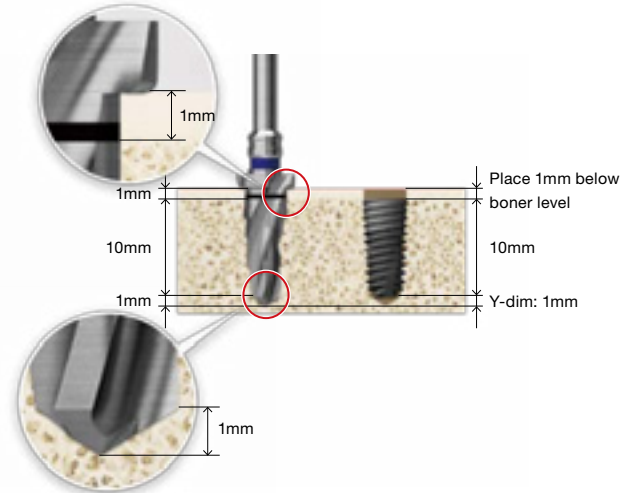

* Y-dim height for each 10mm drill diameter size

Drill diameter	F3.5	F4.0	F4.5	F5.0	F5.5
Y-dim	0.7mm	0.9mm	1mm	1mm	1mm
Drill actual length (mm)	11.7mm	11.9mm	12mm	12mm	12mm

C Drill shape optimized for taper implant placement

- According to the diameter and length of the taper implant, the drill has a multi-tier shape with 3~4 tiers optimized for bone contact. Therefore, it is possible to obtain optimized primary stability.
- Stable placement for implants of all diameters and lengths.
- The multi tier drill has a similar shape as an implant, and therefore the drill hole has an appropriately tight contact with implant.
- The multi tier design of the drills are different for each drill's diameter and length, and therefore providing stable placement torque

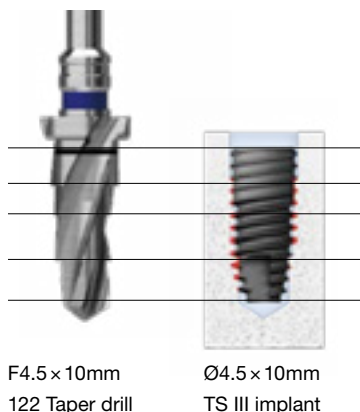



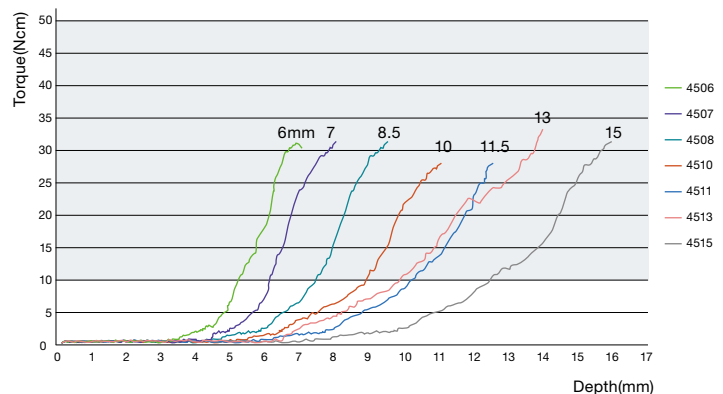





TS III Ø4.5 diameter implant placement torque value by length specification

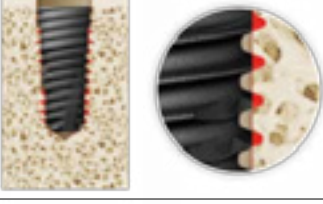

*** Comparison of bone interference by length of a Ø4.5 diameter taper implant**

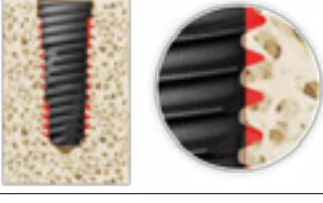
For proper bone interference, select the drill specification that matches the length of the implant to be placed.

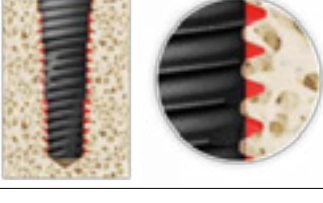
Length	122 Taper drill	Taper drilling hole
7.0		
8.5		
10.0		
11.5		
13.0		

D Excellent cutting power

Drills hard bone easily, prevents bone heating



E Avoid kickbacks

Pilot drill is replaced by multi-stage taper drill

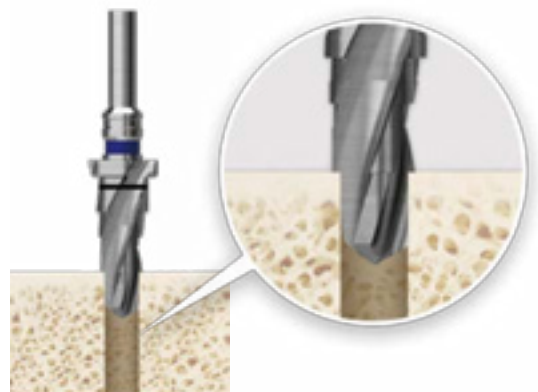

3 Tools of KIT

122 Taper KIT

▨ Drilling tool
(1~10)

▨ Implant placement tool
(11~17)

▨ Superstructure placement tool
(18, 19)

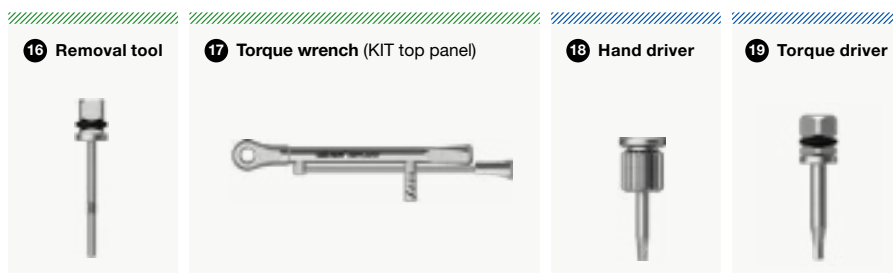
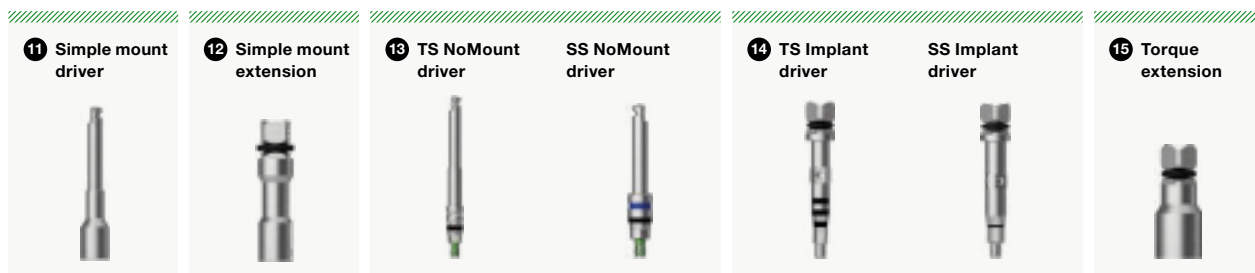
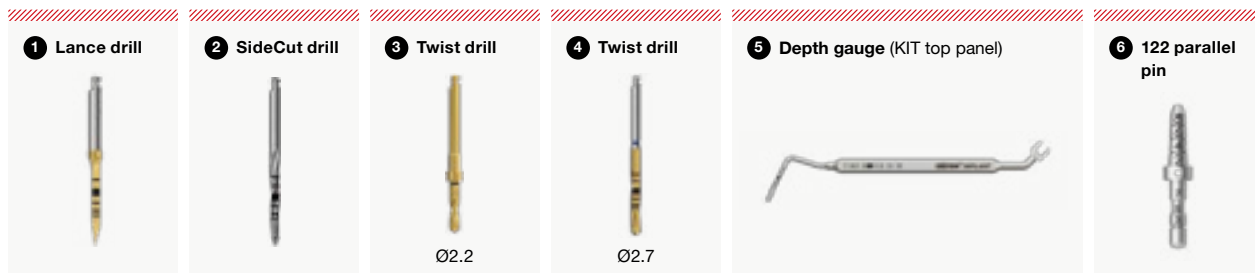
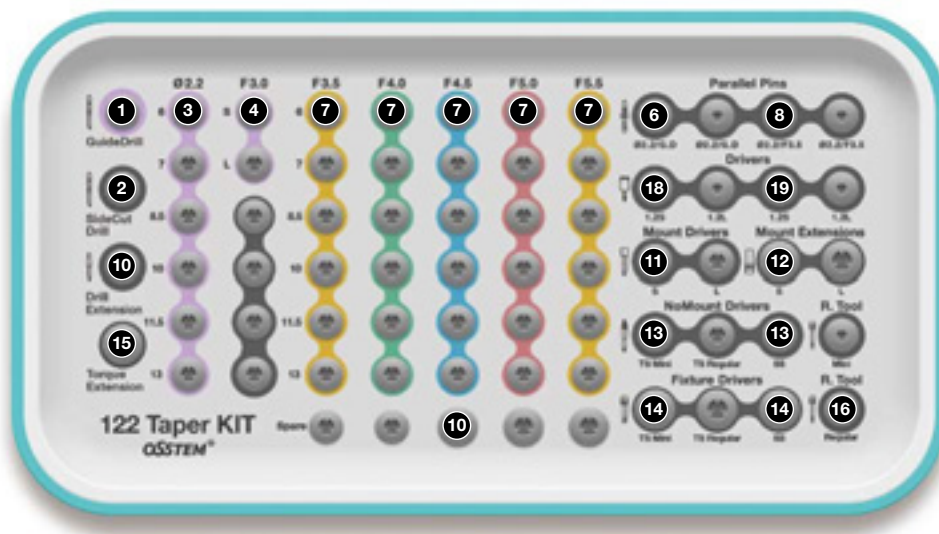

122 Taper full KIT

Drilling tool
(1~10)

Implant placement tool
(11~17)

Superstructure placement tool
(18, 19)

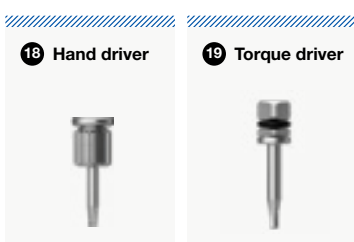
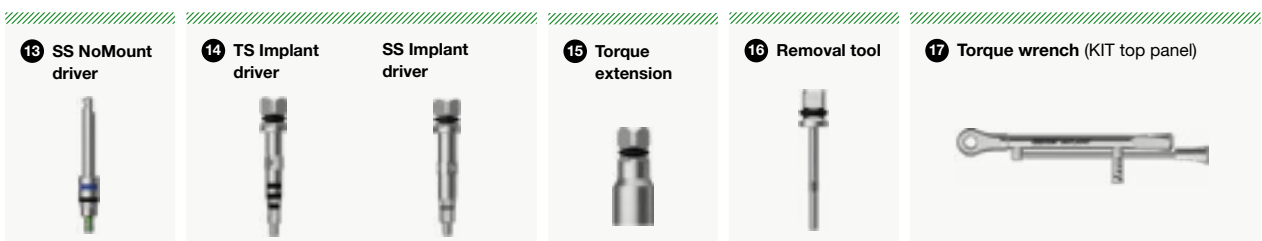
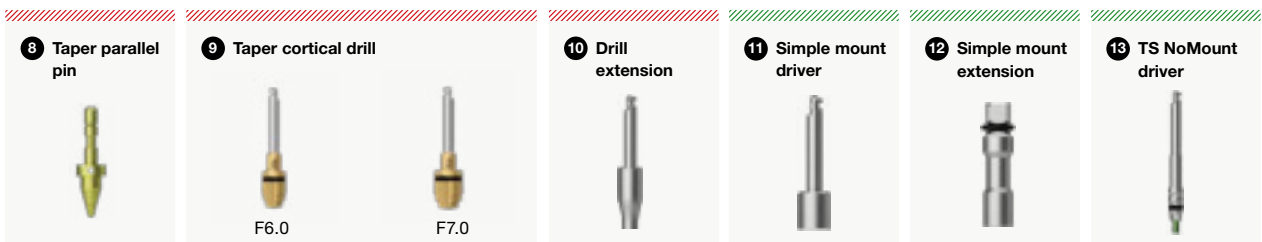
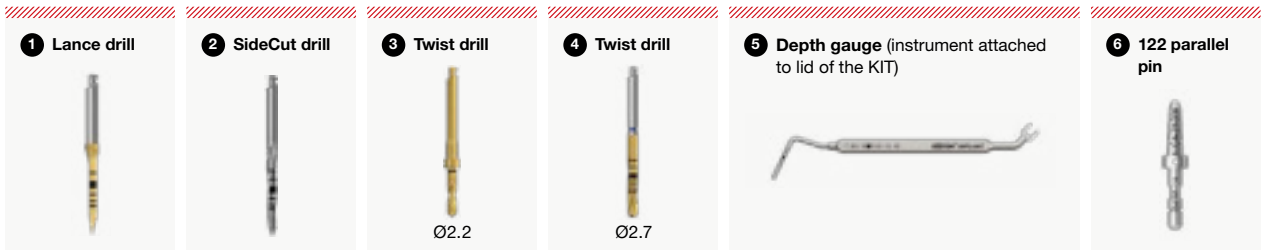
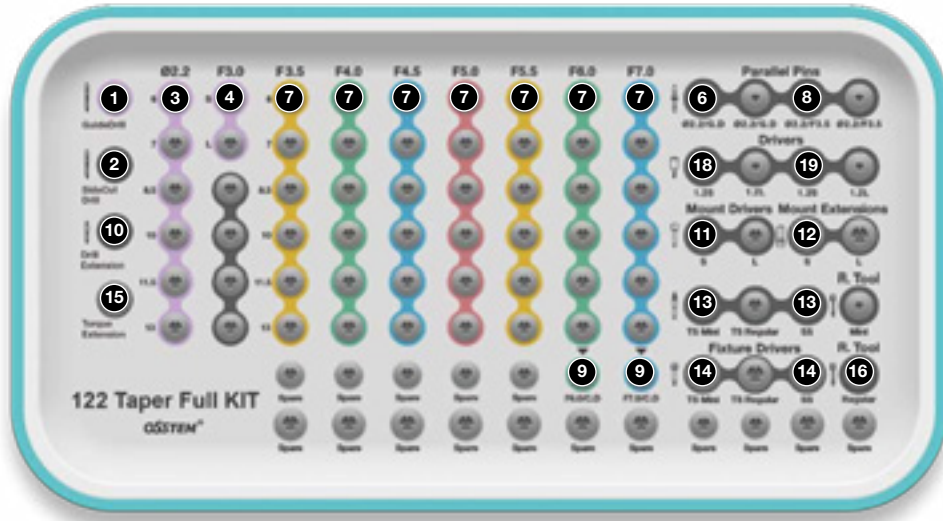

4 User guide of KIT's tools

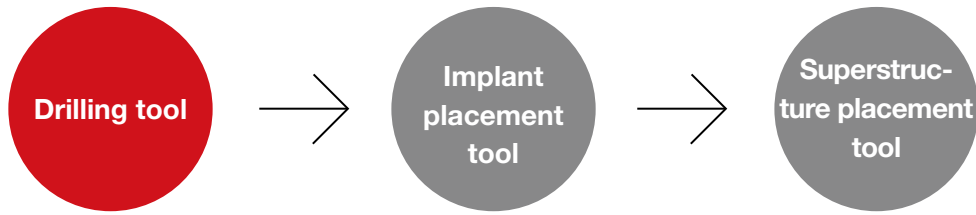

- The KIT has surgical drills for forming drill holes, a depth gauge for gauging drill depth, and parallel pins for checking placement path.
- The Full KIT has surgical drills that enables placing ultra-wide implants (Ø6.0, Ø7.0 diameter) and short implants (6mm long).



1 Lance drill

Drill used for marking the implant's placement position

User guide

- Connect drill to handpiece.
- Use the tip of the drill to mark the implant's placement position.
- The thickness and bone quality of the cortical bone can be assessed during the drilling process.
- Depending on the skill of the surgeon, laser marking lines can be used to drill to the desired placement depth.
- Vertical drilling is easier when using the Ø2.0 SideCut drill on inclined bone.
- Recommended RPM: 1,200~1500rpm

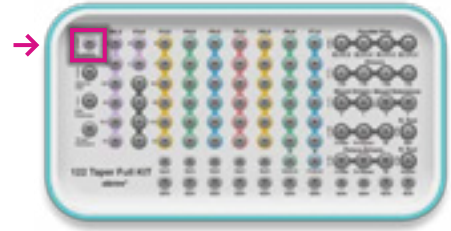

Mark the implant's placement position (marking)

2 SideCut drill

Drill used for correcting the path or ream the drilling site.

User guide

- Connect drill to handpiece.
- Instead of using the Lance drill, it is possible to mark placement position with the tip of the SideCut drill.
- Drill until the marking line that corresponds with the length of the implant to be placed.
- Sidecut drill is recommended in case of reaming drill hole, or correcting a path, or cutting the septal bone of extraction site.
- Recommended RPM is 1,200~1,500rpm.
- Available diameters: Ø2.0



Ø2.0

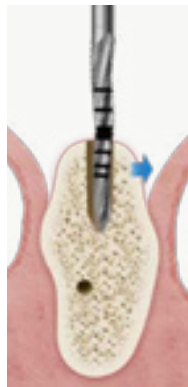

Drill hole reaming

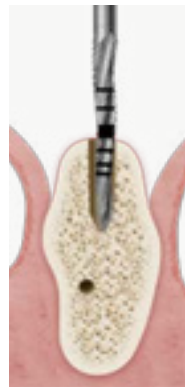

Path correction



Septal bone clean up

3 Ø2.2 Twist drill

Used as an initial drill used after the lance drill when placing a Ø3.0 implant, and the final drill for soft bone

User guide

- Connect the drill that matches the length of the implant to be placed to the handpiece.
- Perform full drilling until stopper.
- Recommended RPM is 800~1,200rpm.
- Available length specifications: 7, 8.5, 10, 11.5, 13mm (122 Taper Full KIT has a 6mm specification)

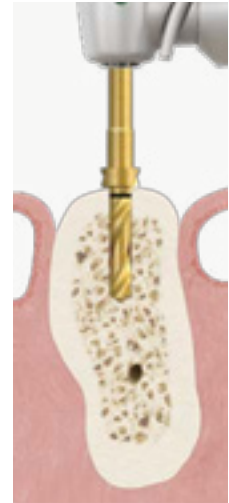
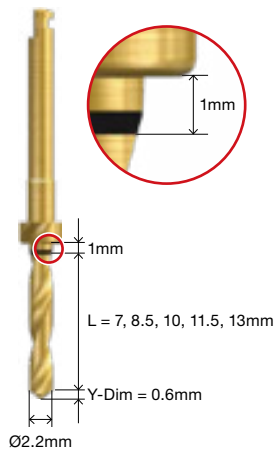
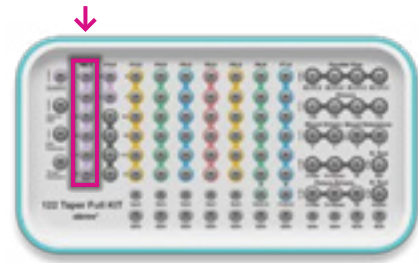

4 Ø2.7 Twist drill

Middle drill used after the initial drill, and final drill when placing a Ø3.0 implant in normal bone

User guide

- Connect drill to handpiece.
- Drill until the marking line that corresponds with the length of the implant to be placed.
- Recommended RPM (depending on bone quality): 800~1,500rpm
- Available length specifications: Short(13mm), long(15mm)

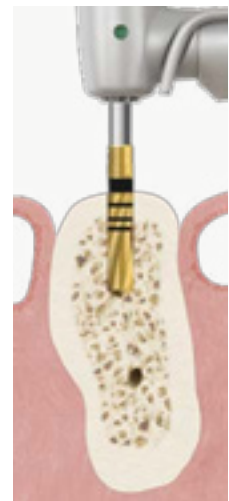
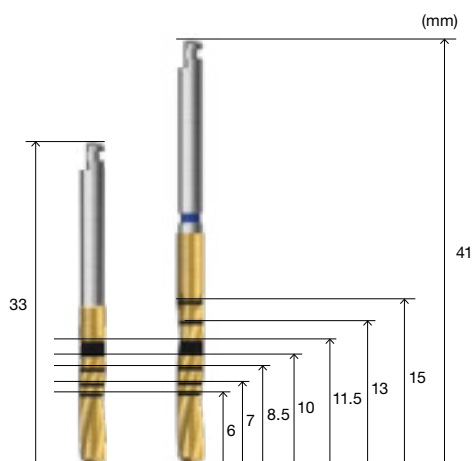
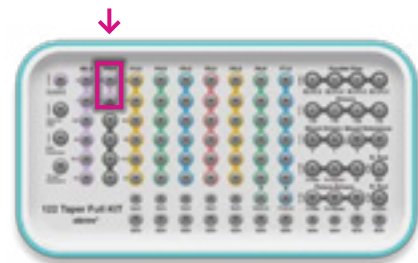

5 Depth gauge

One side of the Depth gauge is for gauging drill hole depth, and the other side is used as open wrench.

User guide

- Used when measuring drilling depth. (grooves in 1mm increments)
- Marking lines of 10mm and 11.5mm are made with one thick line to make length recognition easier.
- When removing Mount from implant, the open wrench grips the octa part of the mount in order to prevent torque application to the implant.

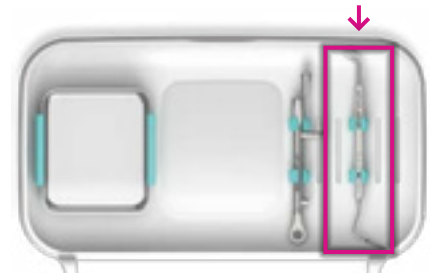

Drill hole depth measurement

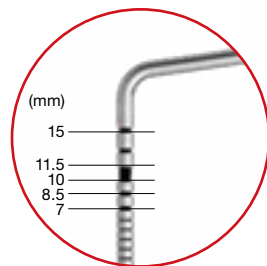

Grooves in 1mm increments

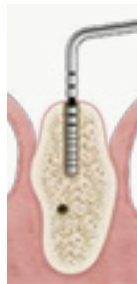

Grip for octa part on top of the mount

6 122 parallel pin

Use to check whether the drill hole is drilled at the desired angle after guide and initial drilling

User guide

- After the guide (lance/SideCut drill) and initial drilling, place it into the hole and check the path.
- The straight part can be used for checking path after $\text{Ø}2.2$ twist drilling, and the tapered part after SideCut drilling.
- Make the patient slightly occlude in order to check path with antagonist teeth.
- The Taper parallel pin might fall into the patient's throat, therefore it is advised to put dental floss through the hole located in the middle.

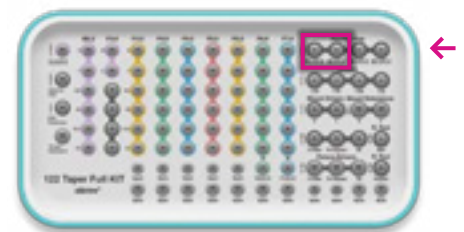

Use after SideCut drill

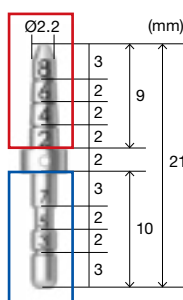

Use after $\text{Ø}2.2$ twist drill



Septal bone removal

7 122 Taper drill

Used to form holes according to implant length and diameter

User guide

- Select appropriate drills for the diameter and length of the implants to be placed.
- Connect drill to handpiece.
- Perform full drilling until stopper.
- Recommended RPM is 800~1,200rpm.
- Available length specifications: 7, 8.5, 10, 11.5, 13mm (122 Taper Full KIT has a 6mm specification)
- Available diameters: F3.5, F4.0, F4.5, F5.0 (122 Taper Full KIT has a F6.0, F7.0 specification)

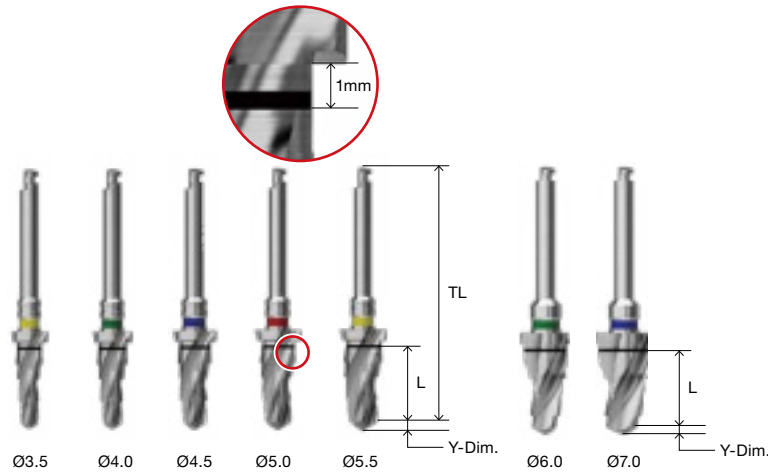
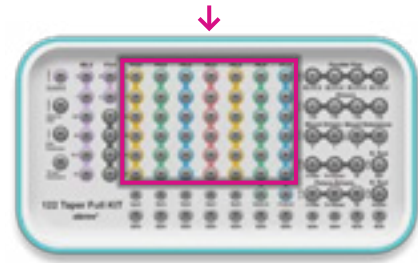

8 Taper parallel pin

Used for checking drilling spot and path after drilling with a 122 taper drill

User guide

- After initial drilling and F3.5 drilling, place it into the drill hole and check the location and path.
- The straight part can be used for checking path after Ø2.2 twist drilling, and the tapered part after F3.5 drilling.
- Make the patient slightly occlude in order to check path with antagonist teeth.
- The Taper parallel pin might fall into the patient's throat, therefore it is advised to put dental floss through the hole located in the middle.
- Available diameters: F3.5

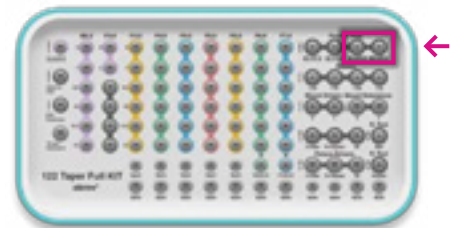

Use after Ø2.2 twist drill

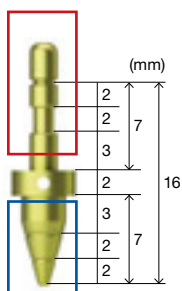

Use after taper drilling

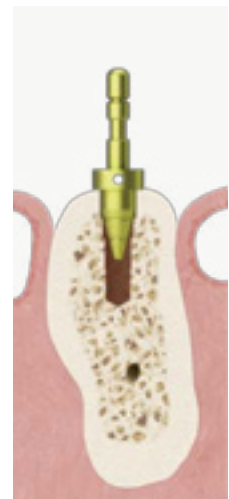

9 Taper cortical drill

Used for cutting cortical bone to reduce torque when placing implants in hard bone (only available in the 122 Taper Full KIT)

User guide

- Select appropriate drill for the diameter of the implant to be placed.
- Connect drill to handpiece.
- Drill until the lower end of the Marking line.
- Recommended RPM is 800~1,200rpm.
- Available diameters: F6.0, F7.0

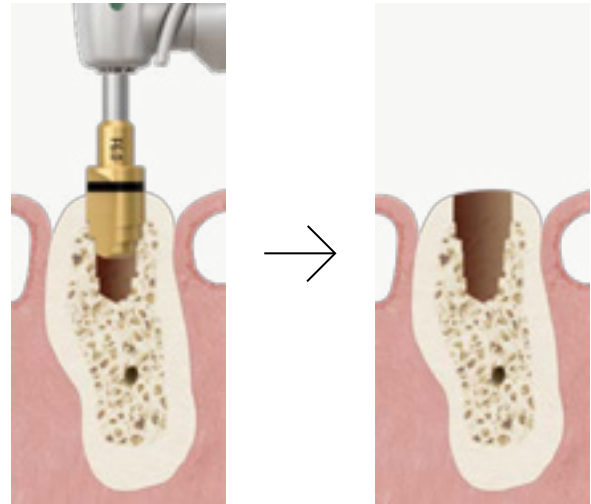
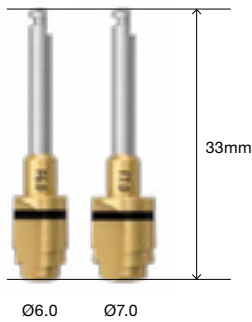
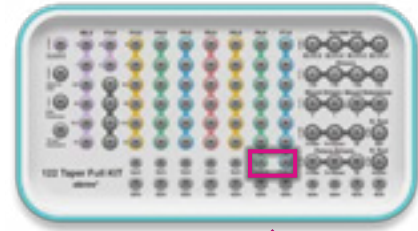

10 Drill extension

Used for extending the length of drills and other hanpiece-using tools in case there is interference from adjacent teeth.

User guide

- Connect the drill extension to the drill and fasten it to the handpiece.
- The Drill extension needs to be properly connected, since it could lead to bending or fracture when applying strong force in case of improper connection.
- Drill at the placement site.
- When using a drill extension, the length of the drill is extended by 16.9mm.

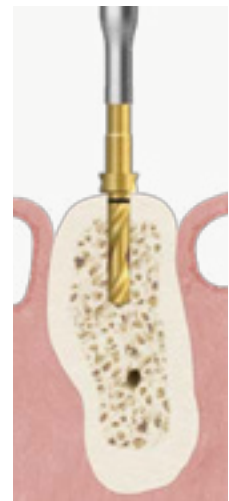
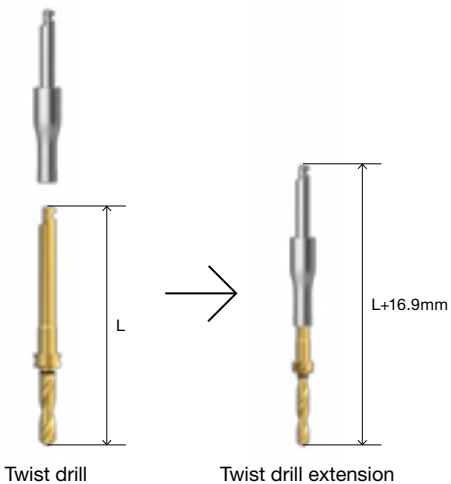

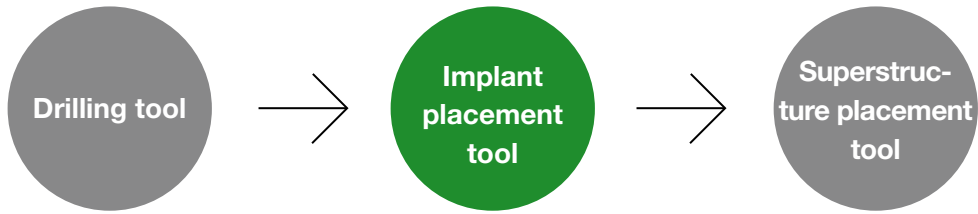

Consists of drivers for placing pre-mount implants and NoMount implants during implant placement, a torque wrench, and a removal tool used in case of mount jamming.



11 Simple mount driver



12 Simple mount extension



13 NoMount driver (TS/SS)



14 Implant driver (TS/SS)



15 Torque extension



16 Removal tool



17 Torque wrench

11 Simple mount driver

Simple mount driver is used for placing pre-mount implant with an engine.

User guide

- Connect the mount driver to the handpiece.
- Connect the mount driver to the implant mount and take out the implant.
- When taking the implant into the mouth, carry it with the implant tip facing up so that it does not fall down.
- Place only approx. 80% of the implant, and adjust the additional depth with the torque wrench.
- Place the implant at a speed of only 50 rpm and torque of 40Ncm.
- Short and long specifications are available.

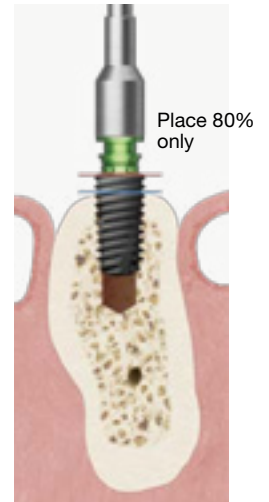
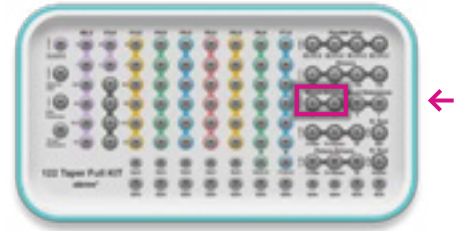

12 Simple mount extension

Tool for adjusting the additional placement depth of pre-mount implants (instrument for torque wrench)

User guide

- Connect the torque wrench to mount extension.
- Connect to Mount of the placed implant. for additional depth control.

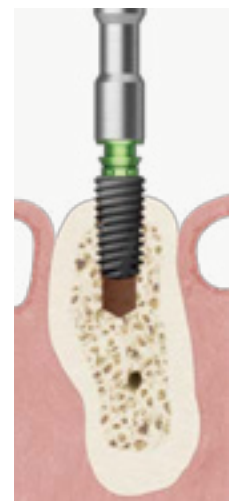
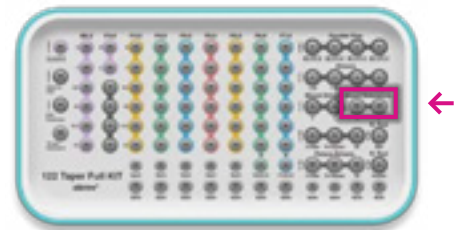
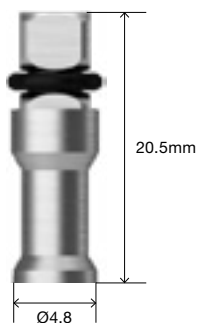

13 NoMount driver (TS/SS)

No Mount driver is used for placing TS or SS NoMount implants with engine

User guide

- Connect the Nomount driver to the handpiece.
- Connect the Nomount driver to the Nomount implant and take out the implant.
- When taking the implant into the mouth, carry it with the implant tip facing up so that it does not fall down.
- Place only approx. 80% of the implant, and adjust the additional depth with the torque wrench.
- Place the implant at a speed of only 50 rpm and torque of 40Ncm.
- There are mini and regular (long) specifications for TS, and one single regular/wide (short) specification for SS.

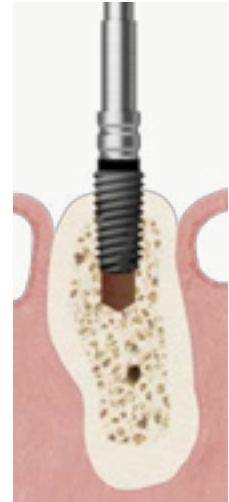
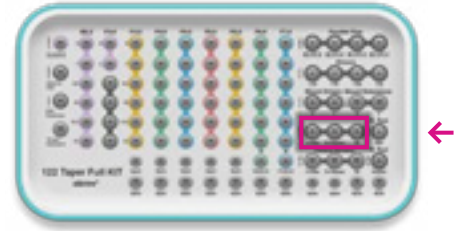
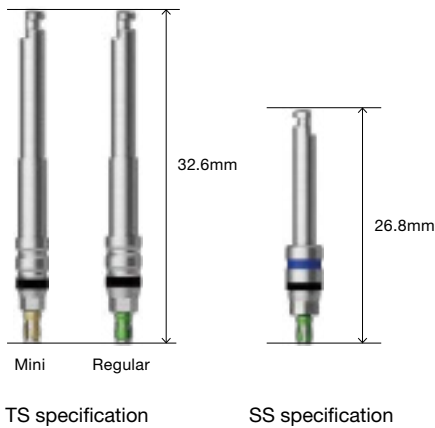

14 Implant driver (TS/SS)

Implant driver is used for adjusting the additional implant depth and hex direction with torque wrench (instrument for torque wrench).

User guide

- Select a implant driver that meets the implant specifications and connect it to the torque wrench.
- Connect it to implant for additional depth control.
- Keep torque value below 30Ncm when placing the implant.
- There are mini and regular (long) specifications for TS, and one single regular/wide (long) specification for SS.

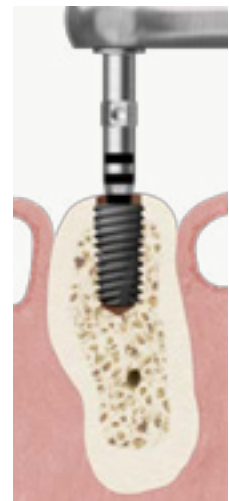
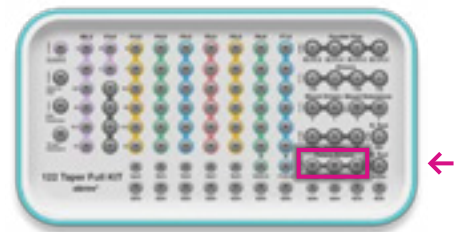
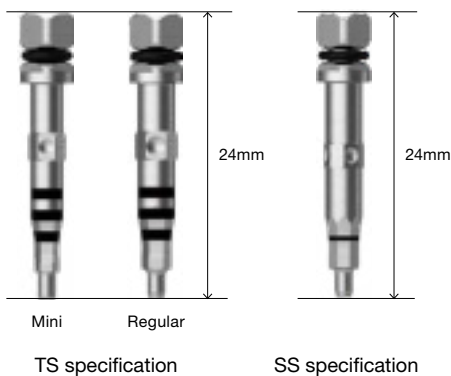

15 Torque extension

A tool that extends the length by 10mm of instruments that are used with the handpiece (Instrument used with torque wrench).

User guide

- Connect the torque extension to the torque wrench.
- Then connect it to tool for torque to extend their length and apply torque.

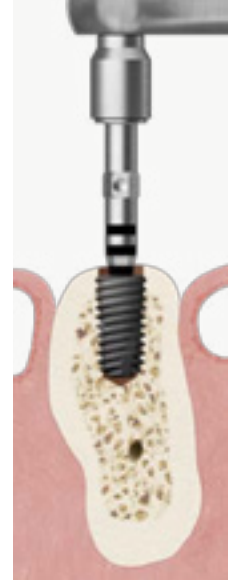
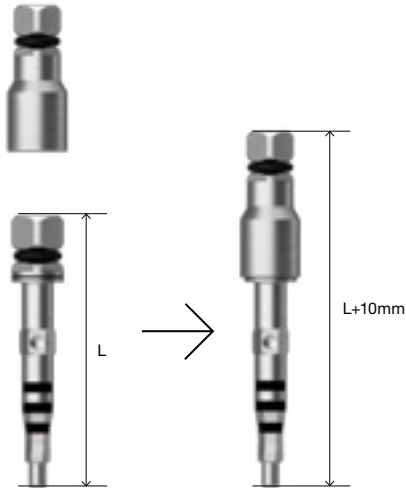
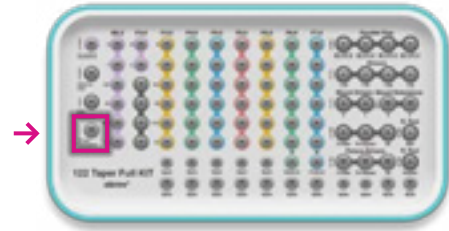

16 Removal tool

A tool that separates the mount in case the mount is jammed and can't be taken out from the placed Pre-Mount implant.

User guide

- Completely remove the mount screw with 1.2 hex hand driver.
- Connect Removal tool to implant mount and rotate clockwise to separate the mount.
- There are two specifications available : mini(TS, US) and regular(TS, SS, US)/wide(SS).

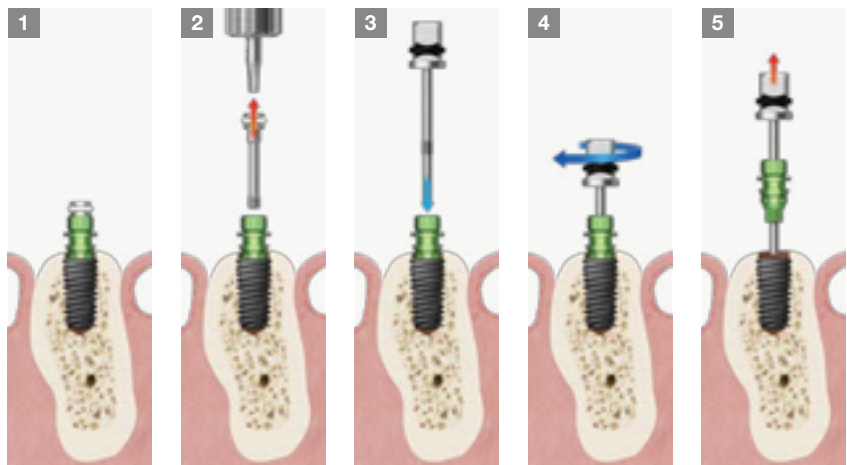
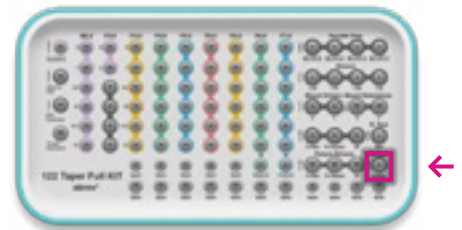

17 Torque wrench

A tool used for adjusting implant placement depth or for applying constant torque on abutment, screw, etc.

User guide

- Pull the bar to match the bar with the torque value you wish to apply, and rotate clockwise for torque application.
- Torque value of 10, 20, and 30Ncm can be applied.
- Keep torque value below 30Ncm when placing the implant.

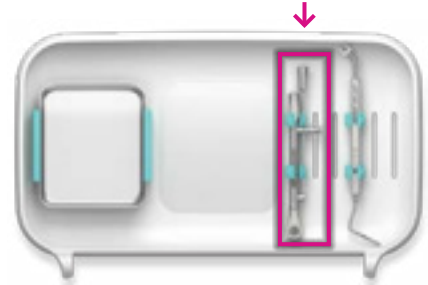

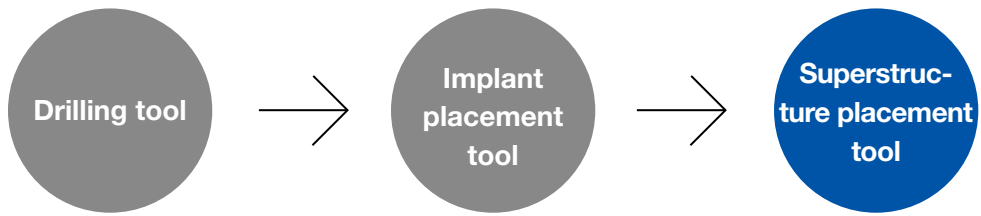

Includes tools used for placing and removing cover screw, healing abutment, and abutment screw after implant placement.



19 Lance drill



20 SideCut drill

18 Hand driver

A manual driver used for tightening or loosening cover screw, healing abutment, and abutment screw after implant placement.

User guide

- Place the hand driver hex into the hex of cover screw or healing abutment.
- To tighten, turn clockwise at 5~8Ncm.
- To loosen, turn counterclockwise.
- If excessive force (above 20Ncm) is applied, hex slip may occur at the tip of the driver or the screw head. Be careful not to apply over-torque.
- When an adult male wears gloves and tightens with his fingers only, he can generate approx. 12 ~ 18Ncm of force (female: 8 to 12 Ncm).
- 1.2 hex (short, long specifications available).

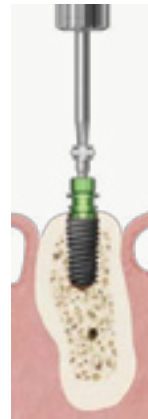
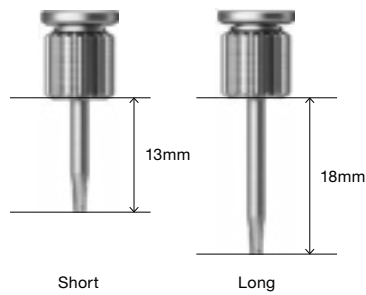

Remove mount



Assemble/remove cover screw

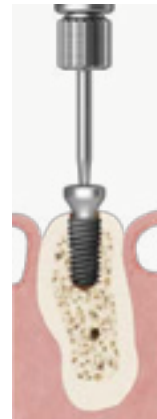

Assemble/remove healing abutment

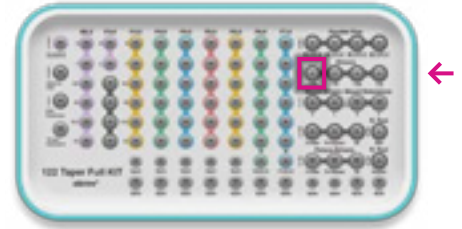

19 Torque driver

A driver used for applying torque to the abutment screw with a torque wrench (instrument for torque wrench)

User guide

- Connect the torque driver to the torque wrench.
- To fasten the abutment screw, rotate clockwise.
- To loosen the abutment screw, rotate counterclockwise.
- 1.2 hex (short, long) specifications available.

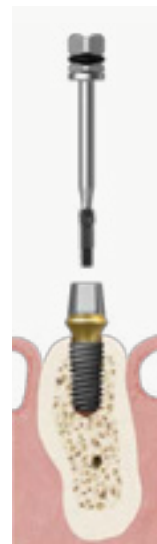
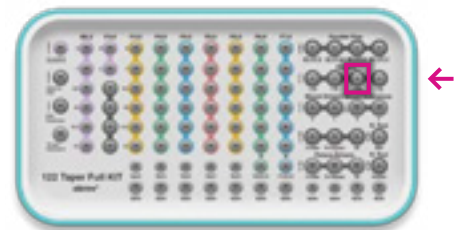
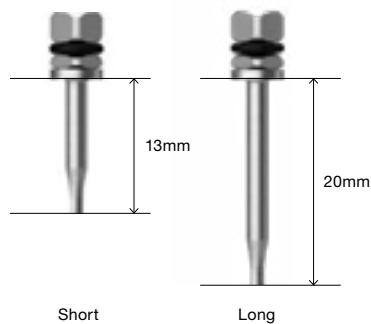

5 KIT sequence

Normal bone TSIII Ø4.5 × 10mm placement

N: Tool number



1 Gingival incision

- Make a gingival incision and a flap in the gingiva and check the surgery region.



2 Mark drilling position (SideCut drill)

- Mark the implant placement site by drilling 2~3mm in cortical bone with the SideCut drill.
- Recommended RPM: 1,200~1,500rpm



3 Initial drilling (SideCut drill)

- Drill until 10mm marking line with the SideCut drill
- The lateral blades on the side make path modification easy
- Recommended RPM: 1,200~1,500 rpm



4 Check depth (Depth gauge)

- After initial drilling, check the depth of the hole and the status of the hole floor.
- * The lower border of the marking lines are the criteria. The single marking line for both 10 and 11.5mm together is bold for easier recognition.



5 Check drilling position and path (parallel pin)

- After initial drilling, place a parallel pin into the hole to check the drilling position and path



6 Expand drill hole (F3.5 × 10mm 122 Taper drill)

- Full drilling up to the stopper with F3.5x10mm 122 taper drill
- Recommended to use drill extension in case of interference from adjacent teeth.
- If the drill gets stuck during the surgery, rotate in reverse mode to remove the drill, then resume drilling
- Recommended RPM: 800~1,200rpm



7 Check drilling position and path (parallel pin)

- Check the position and path of the hole after drilling with an F3.5 drill



8 Perform final drilling (F4.5 × 10mm 122 Taper drill)

- Full drilling up to the stopper with F4.5 x 10mm 122 taper drill
- Recommended RPM: 800~1,200rpm
- * As it is the final stage of determining the size and depth of the hole, exercise more caution.



Implant placement (TSIII Ø4.5 × 10mm)

- Place only 80% of the implant by setting the maximum engine torque to 40Ncm (place implant until only two threads can be seen).
- If the implantation torque is above 55Ncm, bone necrosis might occur or the mount may get stuck.
- If a strange sound can be heard when placing implant., it must be rotated in reverse mode to remove implant.
- Recommended RPM: Max. 50rpm



Remove mount

(when placing a pre-mount implant)

- Remove the mount screw with a 1.2 hex hand driver.
- If the mount screw cannot be removed, it can be separated with a 1.2 torque driver and a torque wrench or a 1.2 machine driver (sold separately) and a handpiece.



- When removing the mount screw, fix the top octa part of the mount with an open wrench so that no torque is applied to the implant, then loosen the screw and remove it.



Adjust placement depth

- After connecting the implant driver to the torque wrench, rotate clockwise to place the implant 1mm below the bone level.
- Recommended torque: Max. 30Ncm



Place cover screw or healing abutment

- Consider primary stability, and fasten the cover screw or healing abutment with a 1.2 hex hand driver.



Suture

- Suture so that soft tissue is not exposed to strong tension
- * In some cases, suture after performing releasing incision or GBR

Quick Guide | TSIII, KSIII, SSIII, USIII (Length: 10mm)

Ø3.0×10mm implant placement

Soft bone Use a drill one specification smaller than the nominal drill

Since bone quality is soft, use a Ø2.2 twist drill, which is smaller than the implant, as the final drill in order to obtain primary stability by increasing bone interference.



Final drill
Ø2.2 twist drill

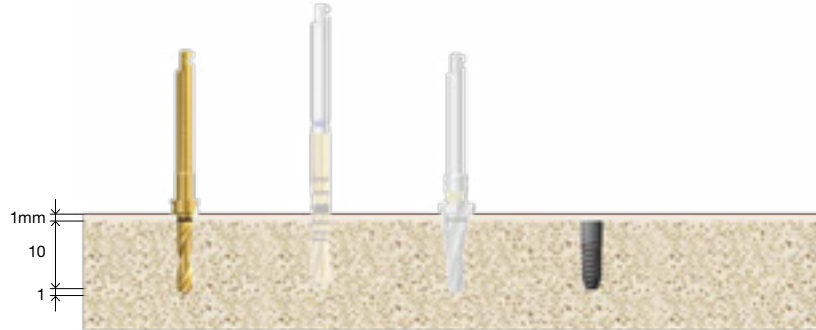

Twist Drill (Ø2.2) Twist Drill (Ø2.7) 122 Taper Drill (F3.5) Implant (Ø3.0)

Final

Normal bone Use nominal drill

As bone quality is appropriate, use a Ø2.7 twist drill, which matches the implant, as final drill to form drill hole.



Final drill
Ø2.7 twist drill

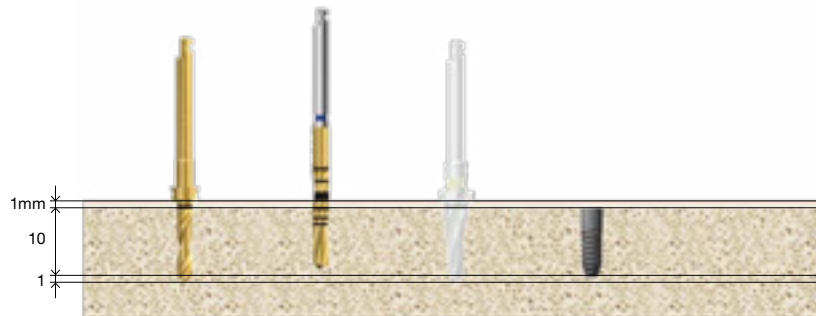

Twist Drill (Ø2.2) Twist Drill (Ø2.7) 122 Taper Drill (F3.5) Implant (Ø3.0)

Final

Hard bone Use a drill one specification larger than the nominal drill

Since bone quality is hard, use a F3.5 122 taper drill that is larger than the implant's diameter as the final drill to prevent osteonecrosis and over-torque.



Final drill
F3.5 122 Taper drill

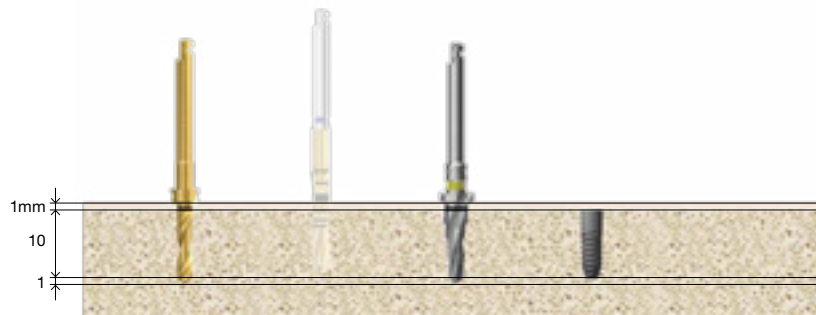

Twist Drill (Ø2.2) Twist Drill (Ø2.7) 122 Taper Drill (F3.5) Implant (Ø3.0)

Final

Ø3.5×10mm implant placement

Soft bone Use a drill one specification smaller than the nominal drill

Since bone quality is soft, use the guide drill, which is smaller than the implant, as the final drill in order to obtain primary stability by increasing bone interference.



Final drill
Guide drill

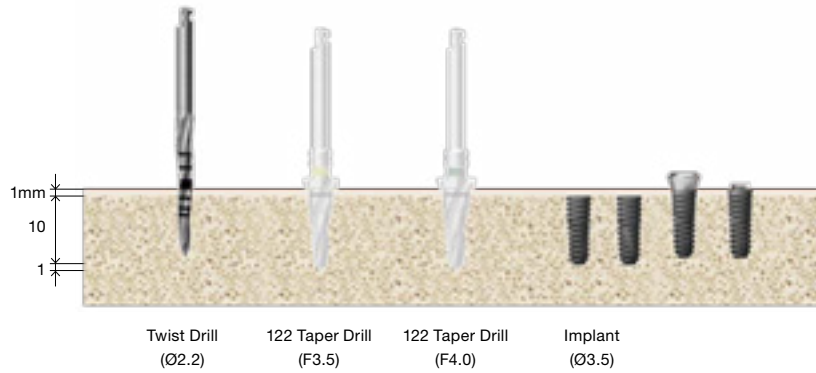

Final

Normal bone Use nominal drill

As bone quality is appropriate, use a F3.5 122 taper drill, which matches the implant's diameter, as the final drill to create a drill hole.



Final drill
F3.5 taper drill

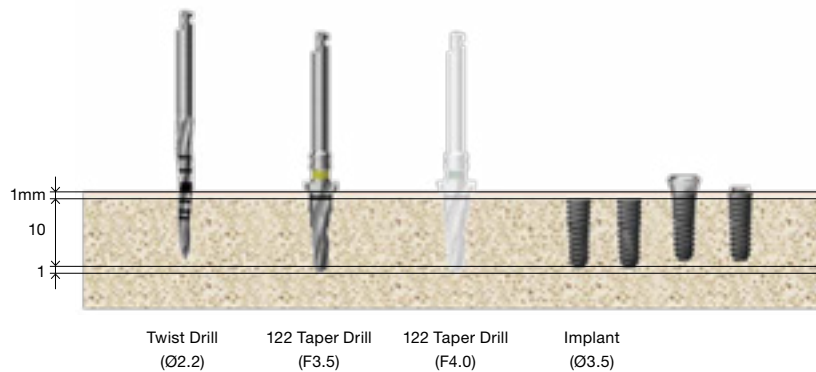

Final

Hard bone Use a drill one specification larger than the nominal drill

Since bone quality is hard, use a F4.0 122 taper drill that is larger than the implant's diameter as the final drill to prevent osteonecrosis and over-torque.



Final drill
F4.0 122 Taper drill

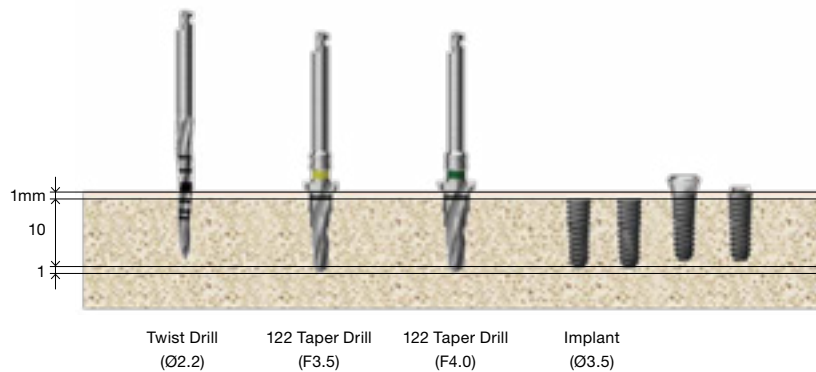

Final

Quick Guide | TSIII, KSIII, SSIII, USIII (Length: 10mm)

Ø4.0×10mm implant placement

Soft bone Use a drill one specification smaller than the nominal drill

Since bone quality is soft, use a F3.5 122 taper drill, which is smaller than the implant, as the final drill in order to obtain primary stability by increasing bone interference.

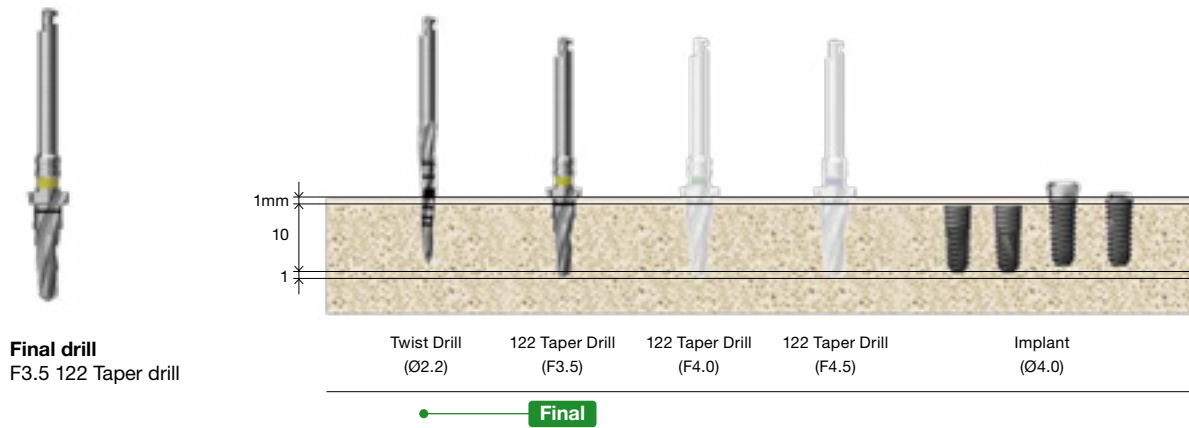

Normal bone Use nominal drill

As bone quality is appropriate, use a F4.0 taper drill, which matches the implant's diameter, as the final drill to create a drill hole.

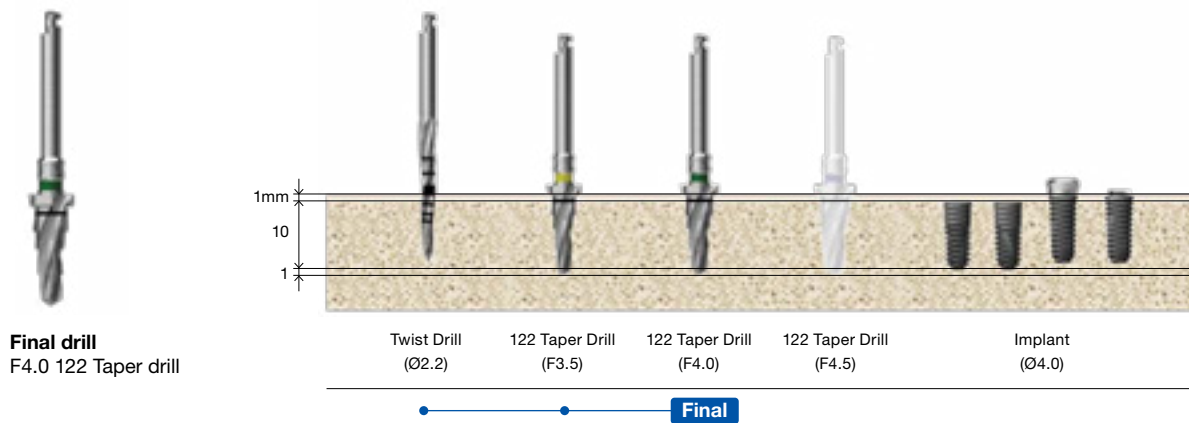

Hard bone Use a drill one specification larger than the nominal drill

Since bone quality is hard, use a F4.0 taper drill and F4.0 taper cortical drill as final drill to prevent osteonecrosis and over-torque.

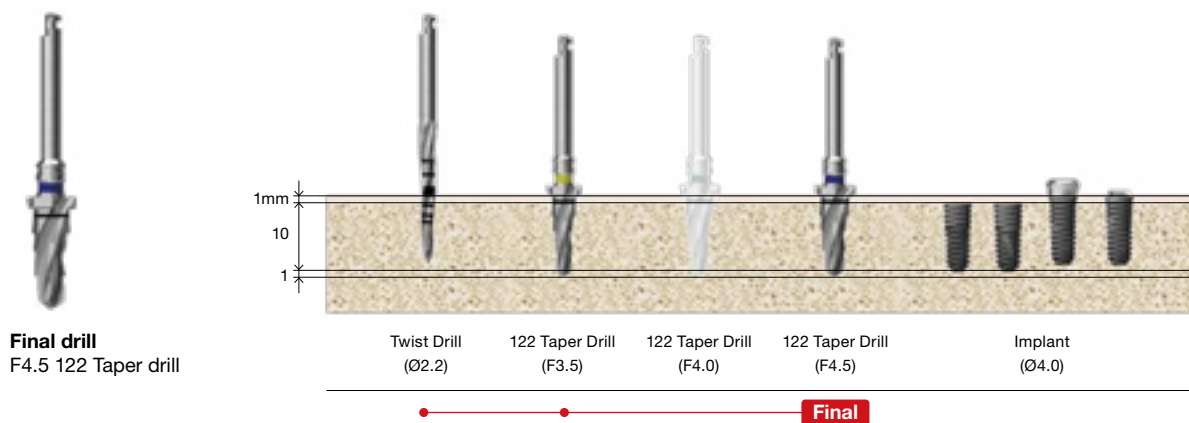

Ø4.5x10mm implant placement

Soft bone Use a drill one specification smaller than the nominal drill

Since bone quality is soft, use a F4.0 122 taper drill, which is smaller than the implant, as the final drill in order to obtain primary stability by increasing bone interference.

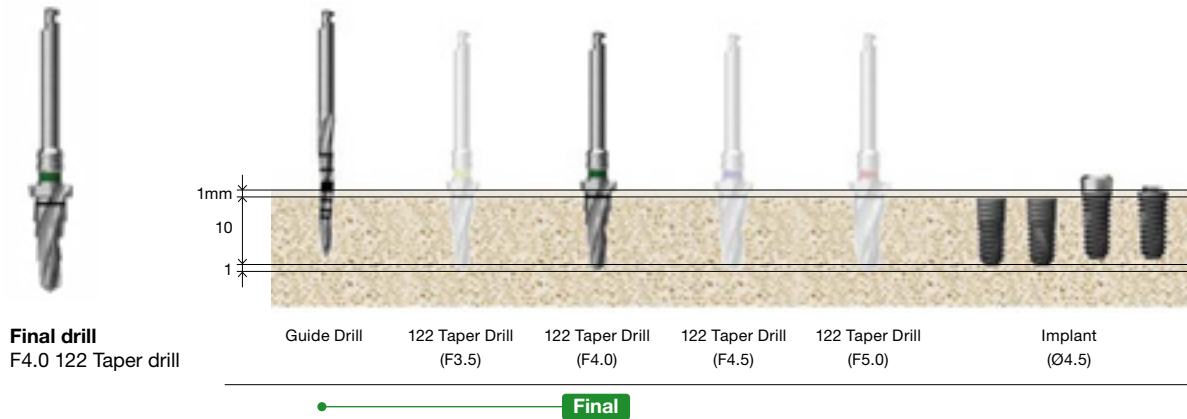

Normal bone Use nominal drill

As bone quality is appropriate, use a F4.5 122 taper drill, which matches the implant's diameter, as the final drill to create a drill hole.

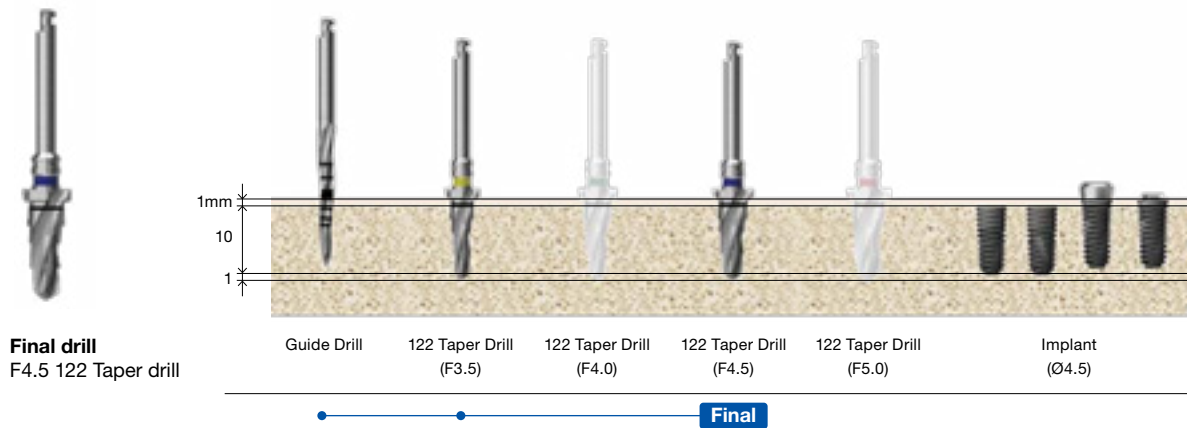

Hard bone Use a drill one specification larger than the nominal drill

Since bone quality is hard, use a F5.0 122 taper drill that is larger than the implant's diameter as the final drill to prevent osteonecrosis and over-torque.

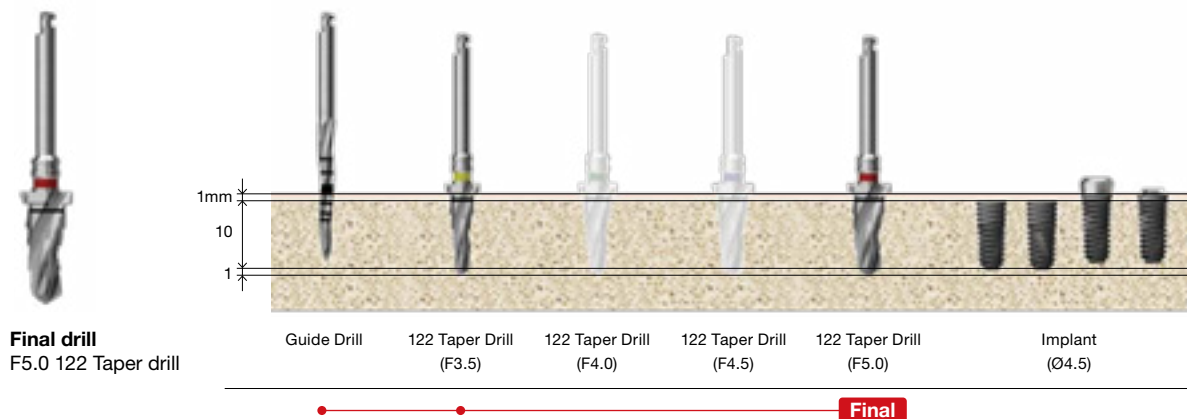

Quick Guide | TSIII, KSIII, SSIII, USIII (Length: 10mm)

Ø5.0×10mm implant placement

Soft bone Use a drill one specification smaller than the nominal drill

Since bone quality is soft, use a F4.5 122 taper drill, which is smaller than the implant, as the final drill in order to obtain primary stability by increasing bone interference.

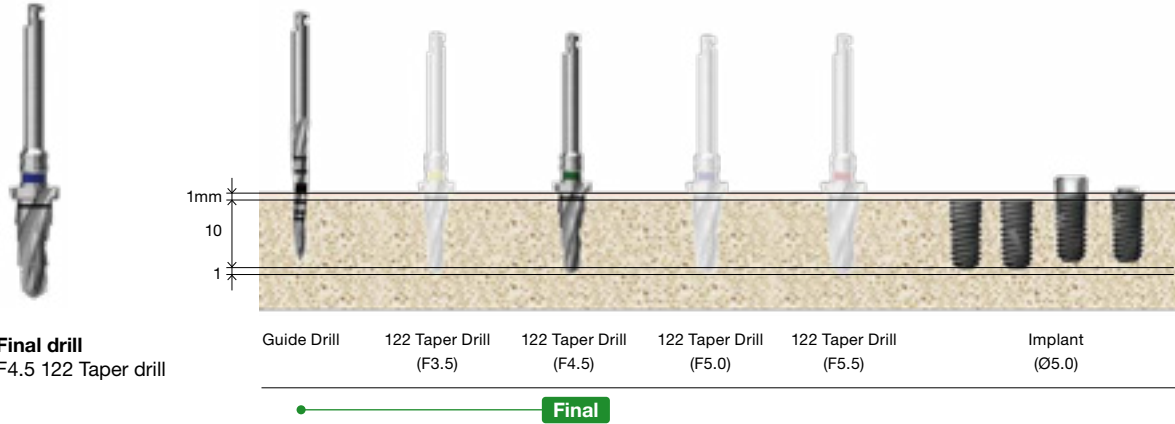

Normal bone Use nominal drill

As bone quality is appropriate, use a F5.0 taper drill, which matches the implant's diameter, as the final drill to create a drill hole.

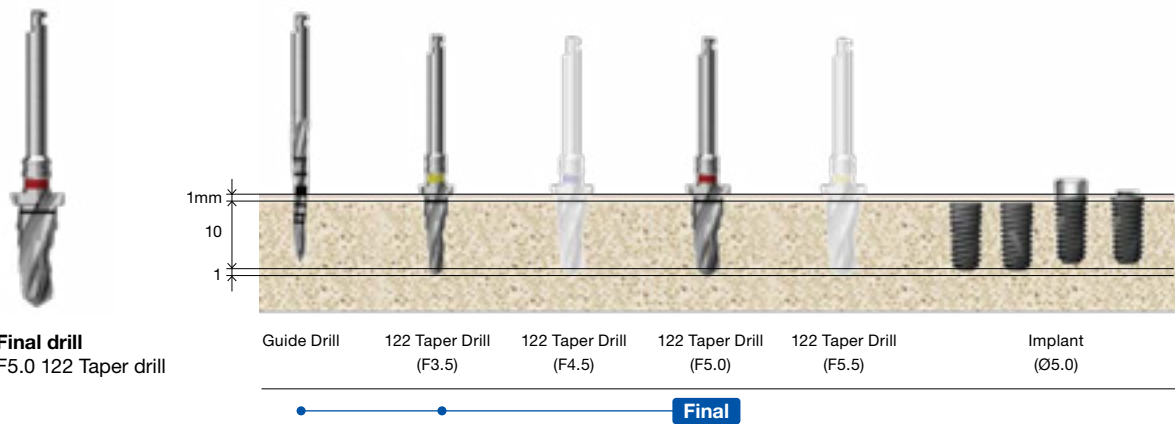

Hard bone Use nominal drill and taper cortical drill

Since bone quality is hard, use a F5.0 taper drill and F5.0 taper cortical drill as final drill to prevent osteonecrosis and over-torque.

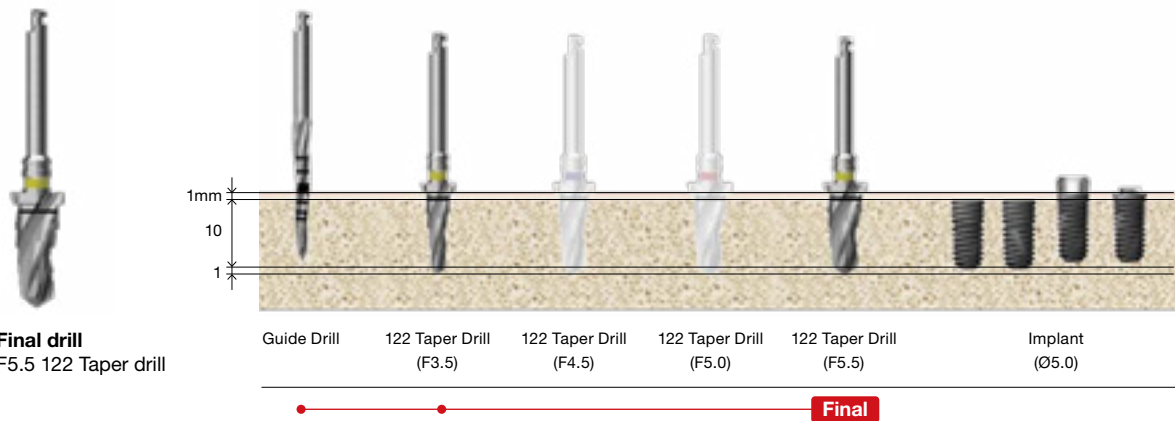

Ø5.5×10mm implant placement

Soft bone Use a drill one specification smaller than the nominal drill

Since bone quality is soft, use a F5.0 122 taper drill, which is smaller than the implant, as the final drill in order to obtain primary stability by increasing bone interference.

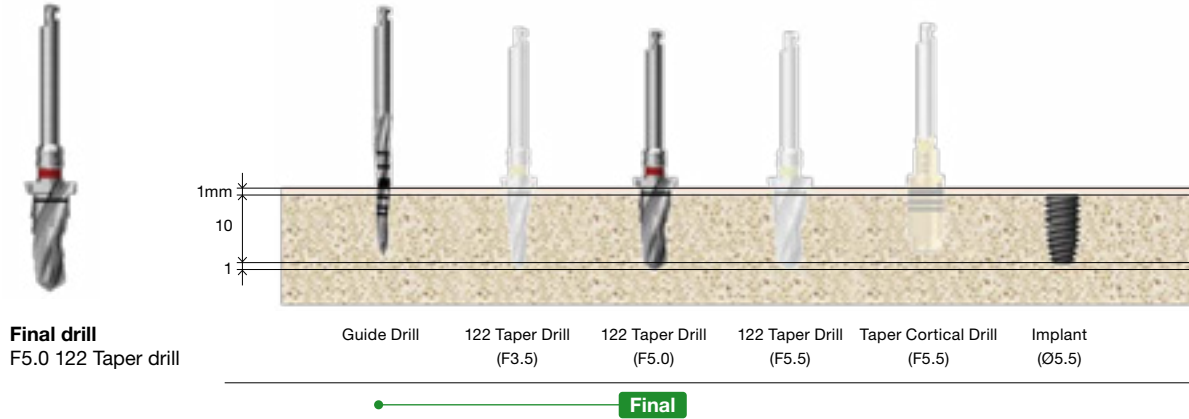

Normal bone Use nominal drill

As bone quality is appropriate, use a F5.5 122 taper drill, which matches the implant's diameter, as the final drill to create a drill hole.

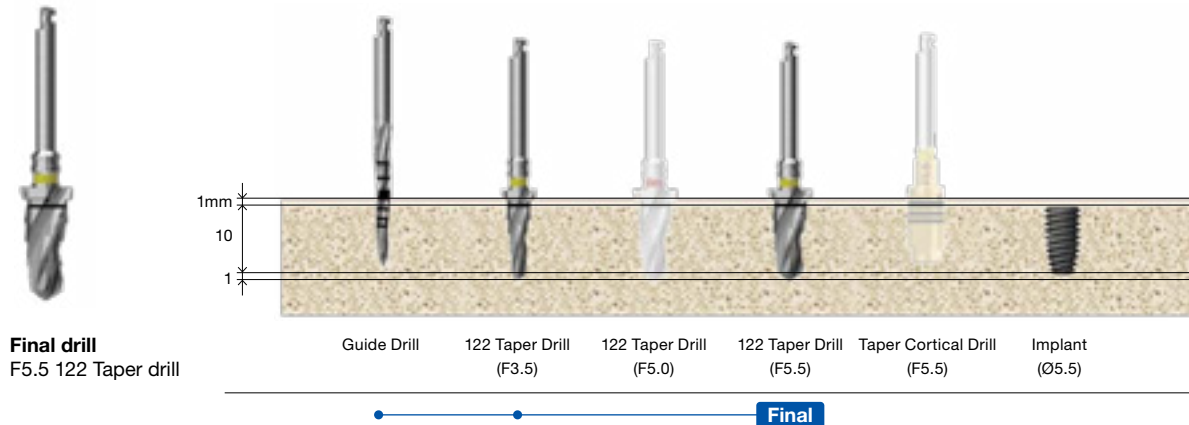

Hard bone Use nominal drill and taper cortical drill

Since bone quality is hard, use a F5.5 x 10mm drill and afterwards the taper cortical drill (option tool) as final drill to prevent osteonecrosis and over-torque.

* Cortical drill is sold separately
* Drill until lower line for 6mm and shorter implants, middle line for 7mm implants, and upper line for 8.5mm and longer implants.

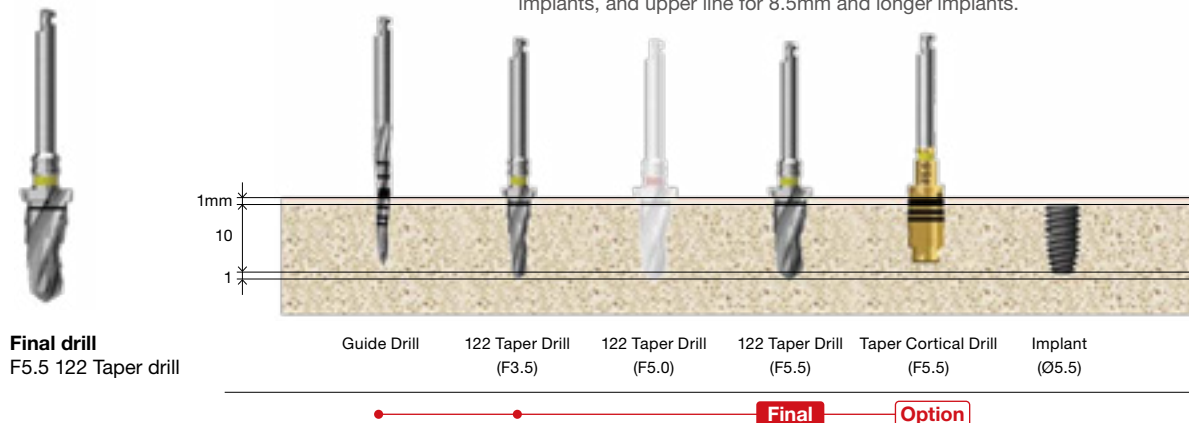

Quick Guide | TSIII, KSIII, SSIII, USIII (Length: 10mm)

Ø6.0×10mm implant placement (122 Taper Full KIT)

Soft bone Use a drill one specification smaller than the nominal drill

Since bone quality is soft, use a F5.5 122 taper drill, which is smaller than the implant, as the final drill in order to obtain primary stability by increasing bone interference.

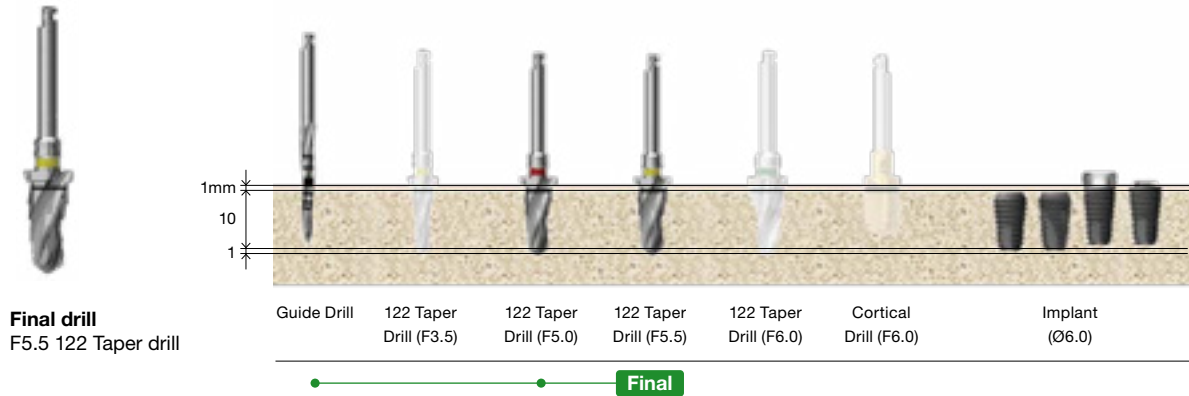

Normal bone Use nominal drill

As bone quality is appropriate, use the F6.0 122 taper drill, which matches the implant's diameter, as the final drill to create a drill hole.

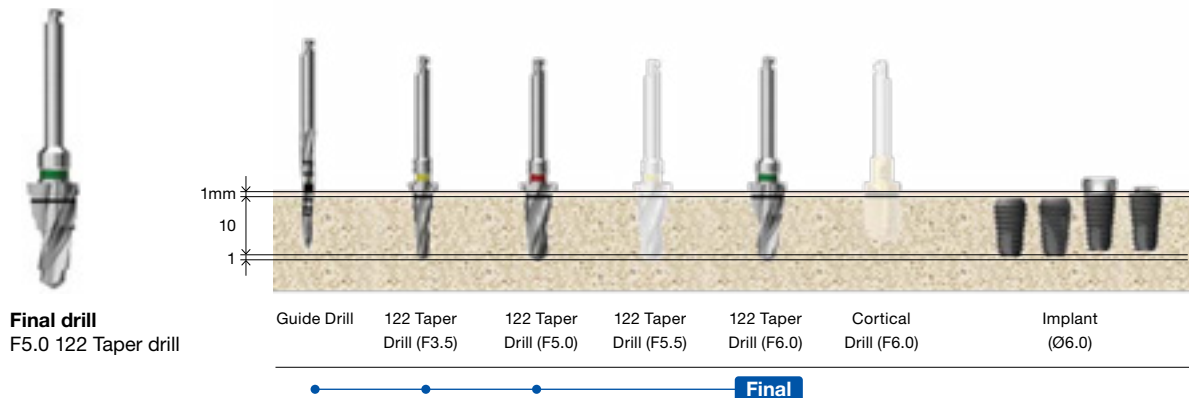

Hard bone Use nominal drill and taper cortical drill

Since bone quality is hard, use a F6.0 122 taper drill and afterwards the 6.0 taper cortical drill, which is larger than the implant diameter, as the final drill to prevent osteonecrosis and over-torque.

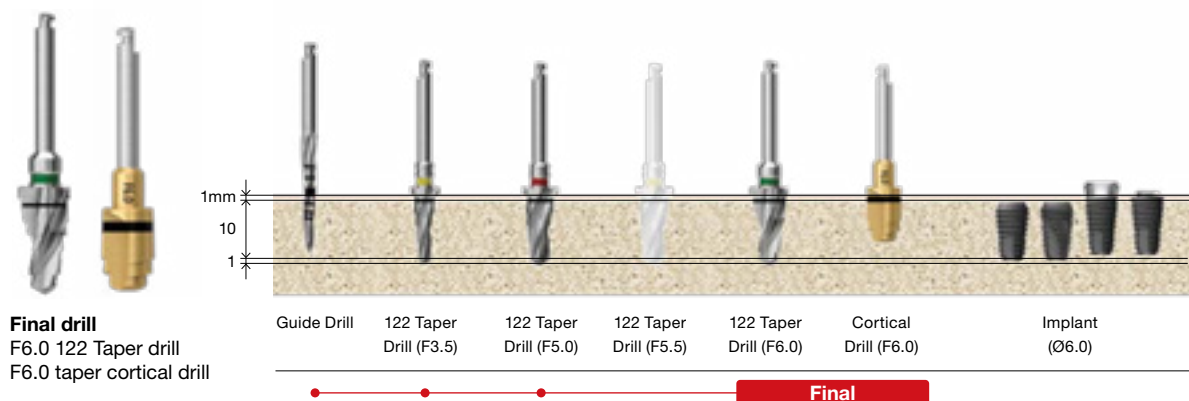

Ø7.0x10mm implant placement (122 Taper Full KIT)

Soft bone Use a drill one specification smaller than the nominal drill

Since bone quality is soft, use the F6.0 x 10mm drill, which is smaller than the implant, as the final drill in order to obtain primary stability by increasing bone interference.

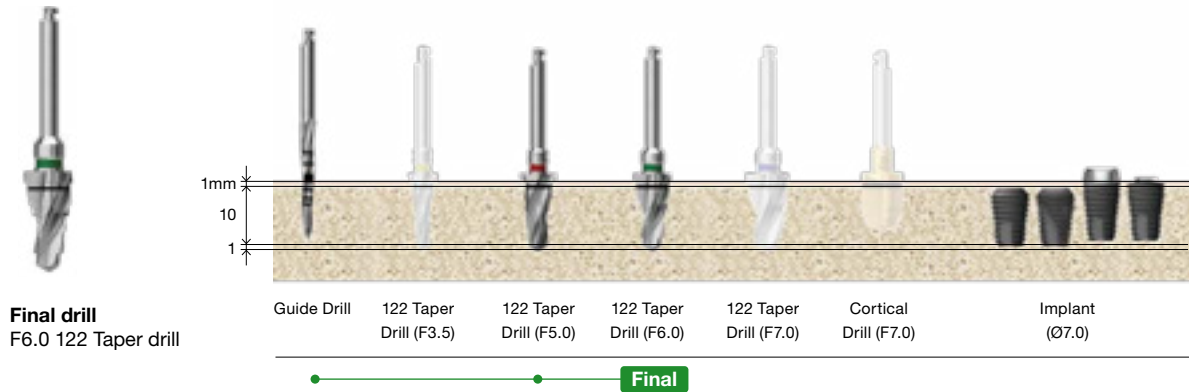

Normal bone Use nominal drill

As bone quality is appropriate, use the F7.0 x 10mm drill, which matches the implant's diameter as the final drill to create a drill hole.

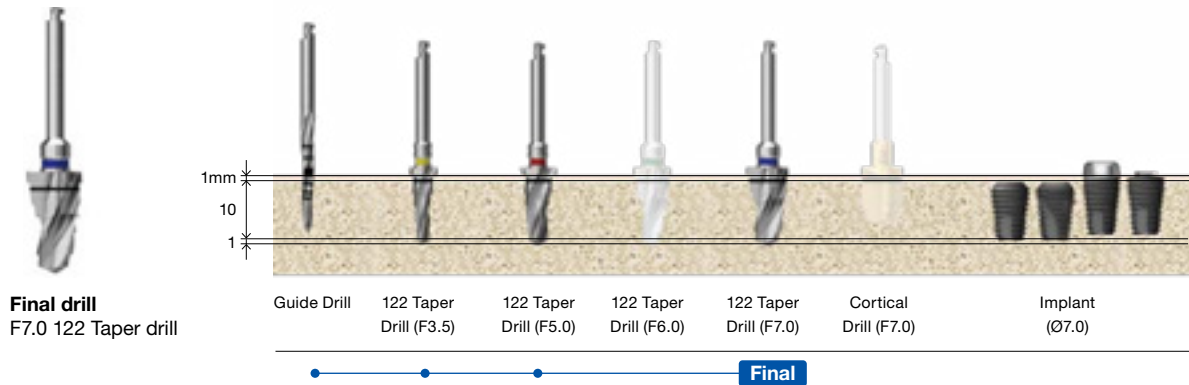

Hard bone Use nominal drill and taper cortical drill

Since bone quality is hard, use a F7.0 122 taper drill and afterwards the 7.0 taper cortical drill, which is larger than the implant diameter, as the final drill to prevent osteonecrosis and over-torque.

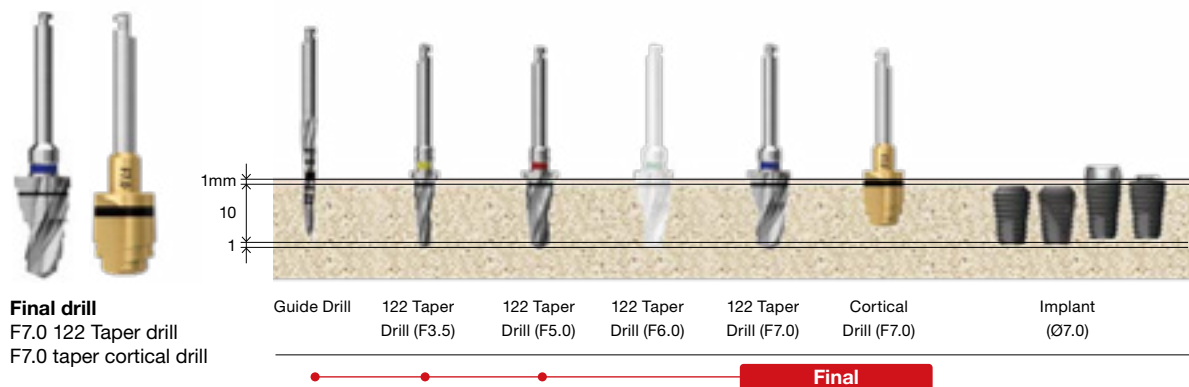

Quick Guide | TSIV, USIV (Length: 10mm)

Ø4.0×10mm implant placement

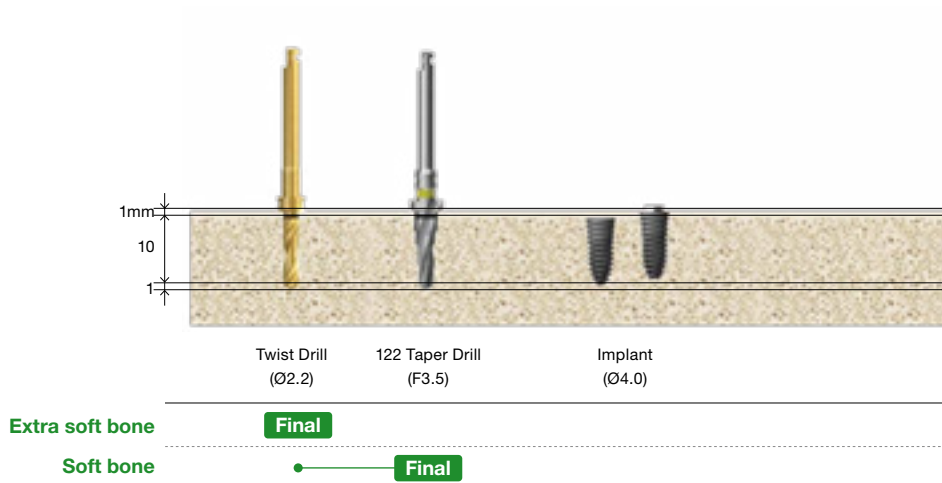

Ø4.5×10mm implant placement

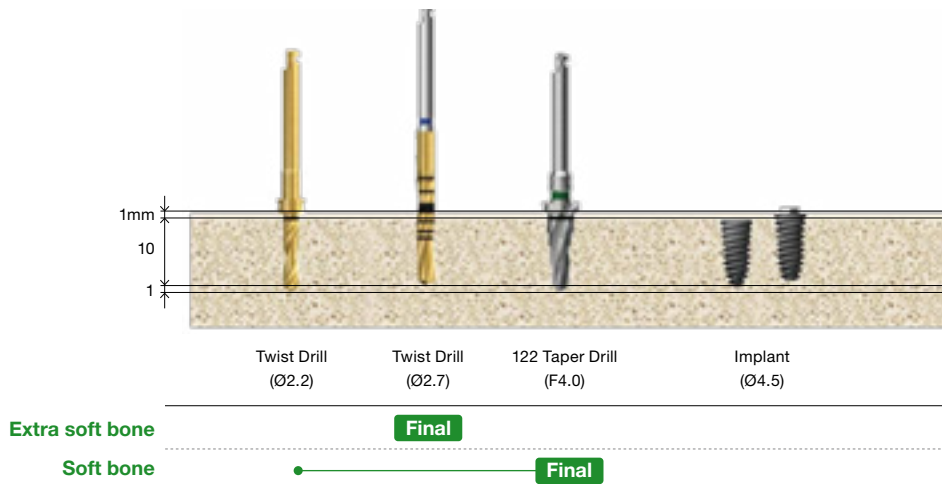

Ø5.0×10mm implant placement

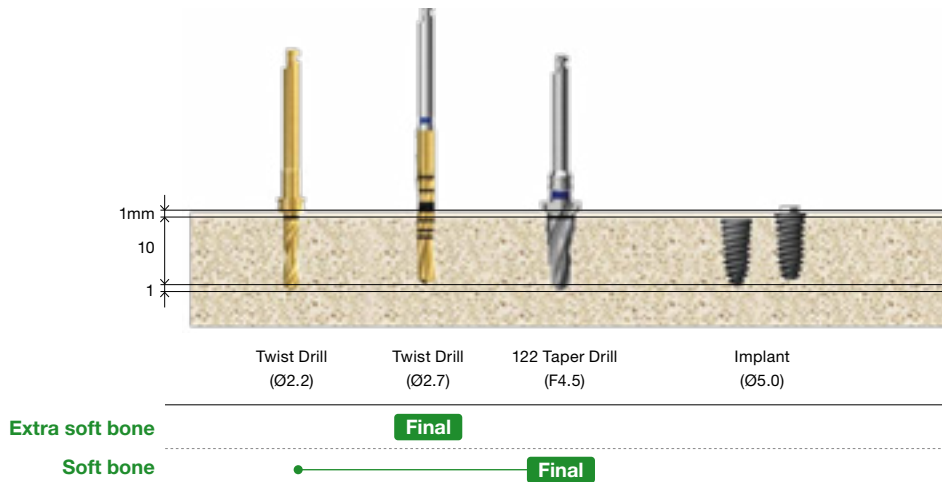

Quick Guide | Ultra-wide TSIV, USIV (Length: 10mm)

Ø6.0×10mm implant placement

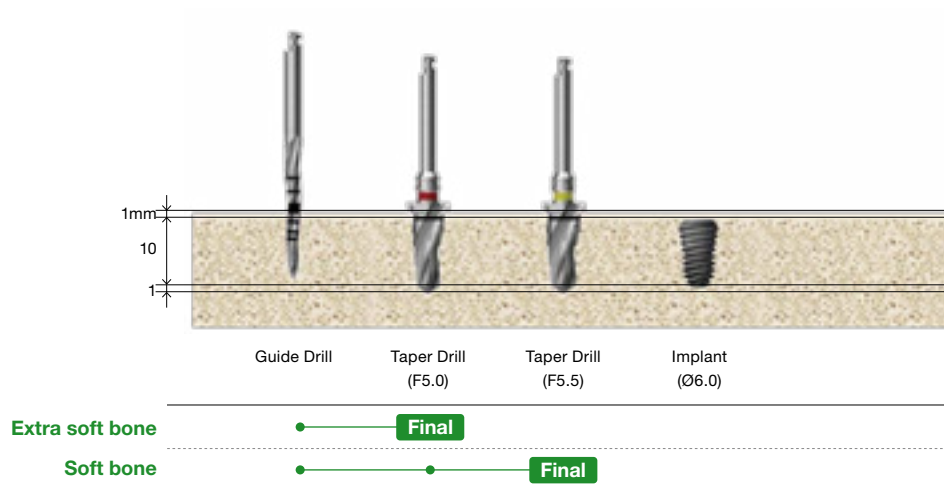

Ø7.0×10mm implant placement

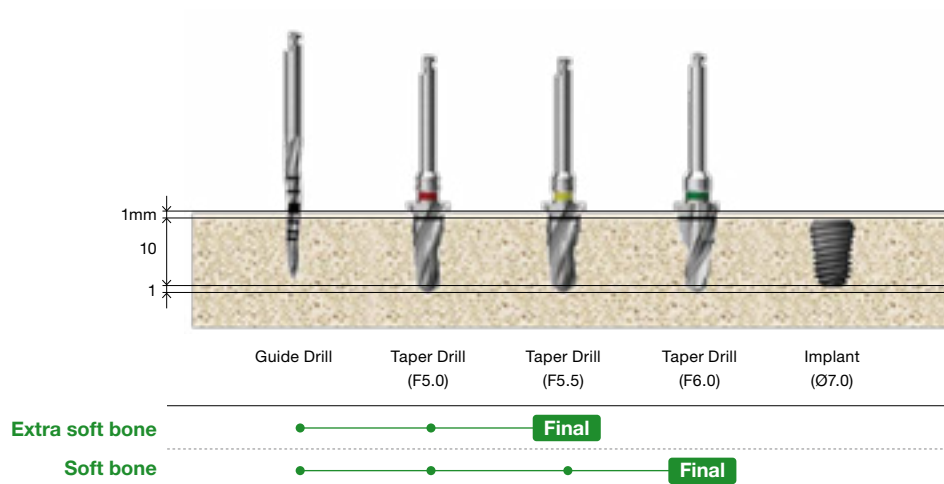

How to take care of the KITS

1



Soak (saline/distilled water)

- Soak the surgical instruments in saline or distilled water

2



Drying (remove moisture)

- Completely dry all drills, drivers, tools, etc by using a towel or fan.

3



First wash

- After surgery, immediately separate and wash all the used instruments.

4

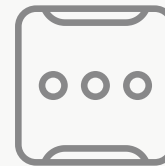

Organize instruments in the KIT

- Place the completely dried instruments in the KIT
- Make sure they are properly placed in the correct location
- Refer to the color coding for reference

5



Second wash

- Thoroughly wash with distilled water or running water to avoid remnants of blood or foreign debris.

6



Sterilization and storage at room temperature

- Wrap clean kit in a sterilization wrap or pouch and place into sterilizer.
- Sterilize temperature - 121°C to 132°C, time duration 15 - 30 minutes, dried and stored at room temperature.
- KIT re-sterilization is recommended immediately before surgery.
- Before and after sterilization, thoroughly dry (the drills will corrode if not fully dried after sterilization)

Important Information and Legal Notices 2026.03 ver.1.1

1. IMPORTANT NOTICE

This catalogue is intended solely as an informational and educational guide for trained dental professionals. It does not replace the applicable Instructions for Use (IFU), product labelling, formal clinical training, treatment planning, or independent professional judgment.

All clinical protocols, drilling sequences, cleaning instructions, sterilization requirements, torque recommendations, indications, contraindications, warnings, and procedural steps must be verified against the current product-specific IFU and the applicable product label for the relevant REF/product code prior to use.

In the event of any discrepancy between this catalogue and the applicable IFU, product labelling, or other official Osstem documentation, the IFU, labelling, and official product documentation shall prevail.

2. PRODUCT INFORMATION, CHANGES, AND AVAILABILITY

All products, specifications, protocols, recommendations, illustrations, and other information contained in this catalogue are subject to change without prior notice.

Not all products may be approved, cleared, released, licensed, or otherwise available in all markets. Product availability, indications, and regulatory status may vary by country. For information on the current product portfolio, approved indications, and local availability, please contact your local Osstem representative or Customer Service and consult the current official Osstem documentation.

3. PROFESSIONAL USE ONLY

Osstem Implant products are intended for use by appropriately trained dental professionals only. Dental implant treatment involves complex professional procedures and requires appropriate education, clinical training, patient selection, treatment planning, and radiographic as well as clinical evaluation.

The suitability of any procedure must be assessed individually for each patient, taking into account anatomy, bone quality and quantity, occlusion, systemic conditions, oral hygiene, compliance, and any other relevant clinical factors.

4. PRODUCT DESCRIPTION AND COMPATIBILITY

Osstem Implant offers implant fixtures, prosthetic components, surgical instruments, and related materials for dental implant treatment. Product codes, specifications, lot numbers, dates of manufacture, and expiration dates, where applicable, must be checked on the product label before use.

Unless expressly stated otherwise in the applicable product documentation, Osstem Implant abutments, prosthetic components, instruments, and related accessories are intended to be used only with compatible Osstem Implant fixtures and components. Use in combination with components or instruments from other manufacturers may result in improper fit, incomplete locking, loosening, fracture, reduced performance, or other clinical complications.

5. STERILITY, CLEANING, REPROCESSING, AND STORAGE

Sterile products supplied in sterile packaging must be used only if the packaging is intact and the expiration date has not passed. If sterile packaging has been opened, damaged, or has expired, the product must not be used.

Single-use products must not be reused, reprocessed, or resterilized.

Reusable instruments must be cleaned, disinfected, inspected, maintained, and sterilized strictly in accordance with the applicable Osstem IFU before reuse.

Products must be stored in accordance with the applicable labelled

storage conditions and protected from moisture, contamination, direct sunlight, and other adverse environmental conditions.

6. CLINICAL PROTOCOLS AND PROCEDURAL GUIDANCE

Any surgical, prosthetic, drilling, insertion, loading, cleaning, maintenance, or other procedural guidance shown in this catalogue is provided for general informational purposes only and must be adapted to the individual patient, the specific product, and the current approved IFU.

Clinicians remain solely responsible for selecting the appropriate treatment protocol and for determining whether the intended procedure, component selection, loading protocol, and clinical application are appropriate for the individual case and within the approved indications for the relevant product.

7. WARNINGS, CONTRAINDICATIONS, AND POSSIBLE COMPLICATIONS

Improper patient selection, inadequate treatment planning, non-compliance with the applicable IFU, improper use, off-label use, product modification, poor oral hygiene, infection, insufficient bone quality or quantity, excessive occlusal loading, or other unfavorable clinical conditions may result in complications or treatment failure.

Possible complications and adverse events may include, without limitation, implant instability or failure, loosening, fracture, bone loss, infection, soft- or hard-tissue complications, prosthetic complications, delayed healing, or the need for revision or removal.

Contraindications and precautions must always be assessed in accordance with the applicable Osstem product documentation and accepted professional standards of care.

8. INTENDED PURPOSE

The products are tools and instruments for surgical placement of Osstem implant fixtures. The drill is used to make implant sites. The cortical drill and tap removes cortical bones or forms threads on bone for the purpose of preventing excessive torque generated when implanting a fixture on hard bone. The drivers are for the placement of the fixture, and the prosthesis is used for setting. In addition, other instruments and tools will be used as aids in the implant procedure.

The applicable product-specific IFU must always be consulted to confirm the intended purpose, indications, limitations, and approved clinical applications of the relevant product.

9. ACCURACY OF INFORMATION

Although reasonable care has been taken in preparing this catalogue, typographical, editorial, translation, printing, and formatting errors may occur. Information may also become outdated as a result of product updates, regulatory changes, technical revisions, or clinical developments.

No representation is made that this catalogue is complete, current, or error-free in every respect. Users must verify all critical information against the current IFU, product labels, and other official Osstem documentation before clinical use.

10. ILLUSTRATIONS AND EXAMPLES

Product illustrations, diagrams, radiographic examples, case images, and step-by-step demonstrations are for illustrative purposes only. Unless expressly stated otherwise, they are not shown to scale and do not guarantee any clinical outcome.

Example cases do not constitute a promise or representation of treatment success in any individual case.

11. TRADEMARKS AND COMPANY NAMES

All trademarks, trade names, product names, brand names, and company names are the property of their respective owners.

Important Contact Information



International HQ

Osstem Implant Co., Ltd.
3, Magokjungang 12-ro, Gangseo-gu
Seoul 07801, Republic of Korea

☎ +82-2-2016-7000

☎ +82-2-2016-7001

🌐 www.osstem.com



European HQ

Osstem Implant s.r.o.
Radlická 740/113c
158 00 Prague, Czech Republic

☎ +420-296-238-800

✉ info@osstem.eu

🌐 www.osstem.eu



Hiossen HQ

Hiossen Implant Inc.
85 Ben Fairless Drive, Fairless Hills
PA 19030, USA

☎ +1-888-678-0001

✉ master@hiossen.com

🌐 www.hiossen.com



Osstem Pharma HQ

Osstem Pharma Co., Ltd.
123, Gasan digital 2-ro, Geumcheon-gu
Seoul 08505, Republic of Korea

☎ +82-70-5118-0330

☎ +82-70-4369-1930

🌐 www.osstempharma.com



Osstem Orthodontic HQ

OSSTEM Orthodontics Inc.
13, Ojeongongeop-gil, Uiwang-si
Gyeonggi-do 16072, Republic of Korea

☎ +82-31-477-9902

☎ +82-31-477-9904

🌐 www.osstemortho.com

WE ARE GLOBAL

Global Leader in Implant Dentistry

Driven by advanced technology and exceptional product quality, we are exporting to more than 90 countries.



We are on Social Media



/osstem
/osstem-europe
/hiossen



/osstem
/osstem.eu
/hiossenimplants



/osstem
/osstem_europe
/hiossen



/osstemglobal
/@osstem_europe
/@hiossenimplants



OSSTEM[®]
IMPLANT

© Osstem Implant Co., LTD. All rights reserved.

Osstem Implant[®] and/or other trademarks and logos of Osstem Implant[®] mentioned herein are trademarks or registered trademarks of Osstem Implant Co., Ltd. and/or its affiliates. For dental professionals only. Informations in this document are provided for general information purposes and do not constitute medical advice. Specifications, content and availability are subject to change without notice. Errors and omissions excepted.