

**OSSTEM<sup>®</sup>**  
IMPLANT

# Surgical Manual

## **KS Implant** System

# Introduction

## Welcome,

and thank you for choosing Osstem Implant products. This catalogue is designed to support dental professionals with product information, clinical workflows, and practical guidance for daily use. It is important to inform patients about the option of dental implant treatment and the potential benefits it may provide. For further information, please contact your local Osstem representative.

## Important Notice

This document is provided for **informational and educational purposes only** and does not replace the applicable product label, the current product-specific Instructions for Use (IFU), formal clinical training, or independent professional judgment. All product information, specifications, and protocols are subject to change without notice. Not all products may be approved, cleared, released, licensed, or available in all markets. Product illustrations are not shown to scale. Despite careful preparation of this catalogue, typographical, editorial, translation, or printing errors may occur. **All critical information must be verified against the current product-specific IFU and product label before use.**

## Electronic IFU (per (EU) 2021/2226)

- Surgical Drill & KIT System is eligible for provision of electronic instructions for use (e-IFU) under Regulation (EU) 2021/2226 for professional users.
- e-IFUs are available at [website URL: [ifu.osstem.com](http://ifu.osstem.com)] in the official languages required by the Member State(s) where the device is placed on the market.
- The e-IFU content is consistent with the paper version; all updates are promptly reflected in both versions.
- If requested, a paper copy of the IFU will be supplied free of charge, within 7 calendar days.
- The e-IFU website maintains historical versions for traceability of all previously applicable instructions.
- Labeling on the product/package indicates the provision of e-IFU and how to access it online.

## Surgical Manual | English Edition

**Publication date:** April 2026

**Publisher:** Osstem Europe s.r.o.  
Radlická 740/113c  
158 00 Prague, Czech Republic

**Note:** *This brochure is based on the global 2021 Osstem Surgical Manual and has been visually revised and adapted for the European market. Product availability and specifications may vary by country and are subject to change without notice. Images are for illustrative purposes only. For professional use only.*

# KS Implant

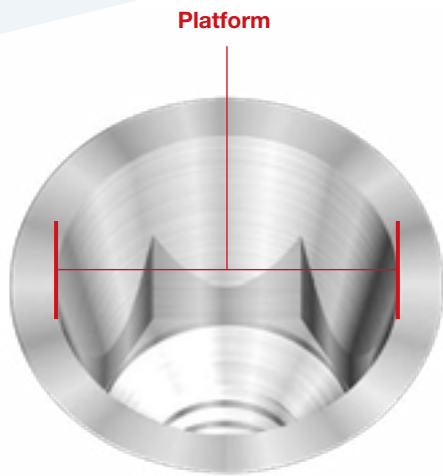

## Concept

- Internal hex submerged Implant
- 15° morse taper
- 1-stage surgery / 2-stage surgery
- Applicable to cases requiring bone grafting

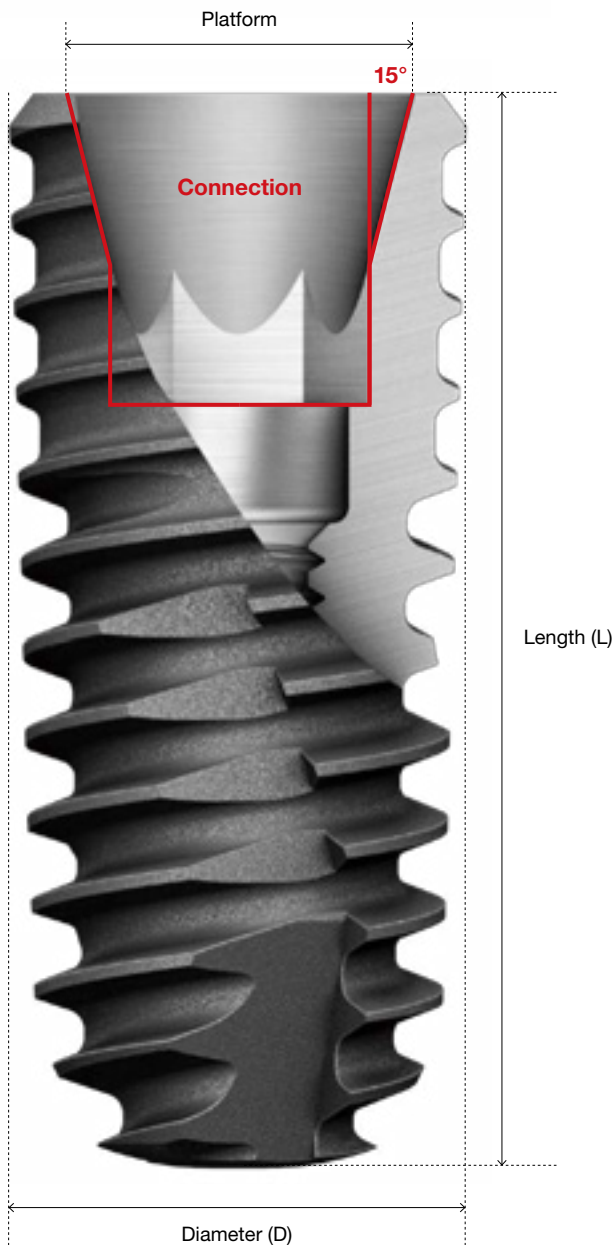

## Platform (single platform)

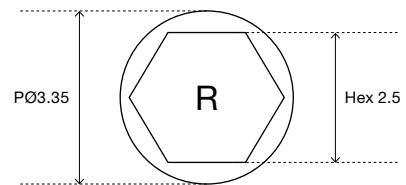

Regular Ø3.3, hex 2.1

# 1 KS Implant placement protocol

## A Placement position

### Mesio-distal position

- Implant should be positioned in the center of the mesiodistal width of the final prosthesis.
- Distance between natural teeth and implant: Min. 1.5mm [▶ Placement position p.8](#)

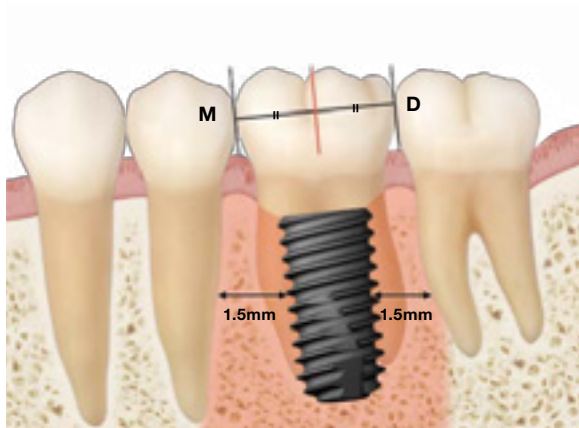

### Bucco-lingual position

- Implant should be positioned in the center of the final prosthesis.
- Here, since the screw hole is positioned at the center, a screw-type or ER-type prosthesis can be fabricated.

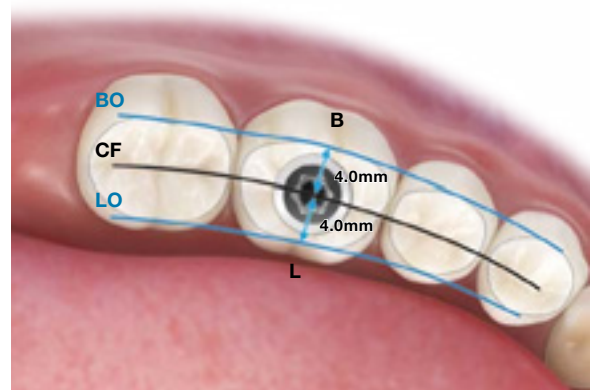

### Common mistakes

- The implant is placed with bias into the mesial from the center of the natural tooth.

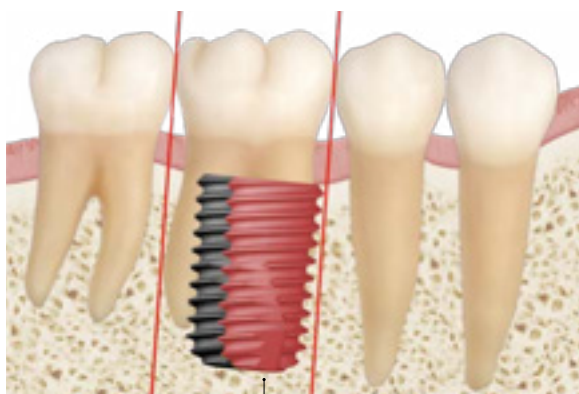

The implant is placed with bias into the mesial

## B Placement direction

### Mesio-distal position

- Guided to place the implant's central axis is headed towards the cusp of the natural antagonist tooth.

▶ Placement direction : p.16

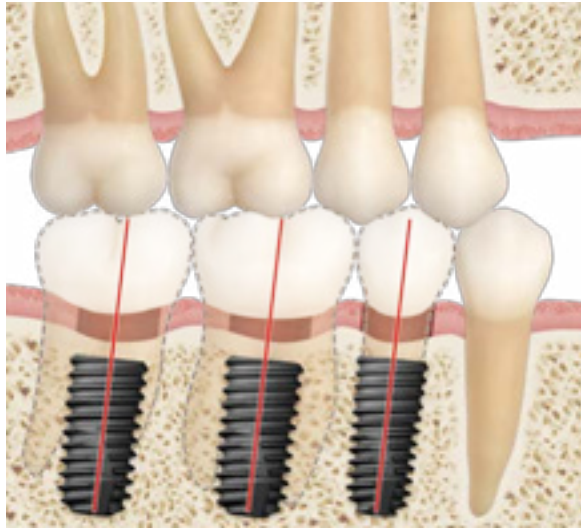

### Bucco-lingual position

- Guided to place the implant's central axis is headed towards the interdental space of the natural antagonist teeth.

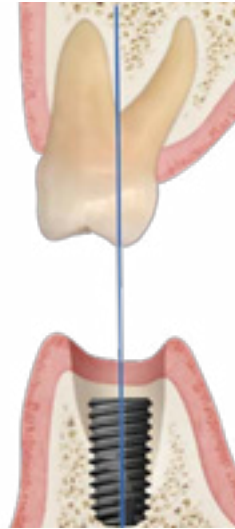

### Common mistakes

- In the Panorama, the implant appears to have been placed correctly, but the apex has a lingual bias.



Appears correct in the Panorama

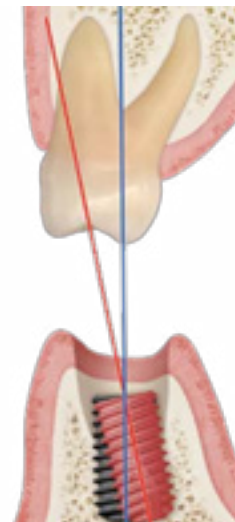

Viewing from a buccolingual direction, the apex has a lingual bias

## C Placement depth

- Placement depth considering the biological width: Secure primary stability and adjust placement depth considering the biological width [▶ Biological width p.26](#)

If thickness is sufficient at 3~4mm, additional bone resorption does not occur.

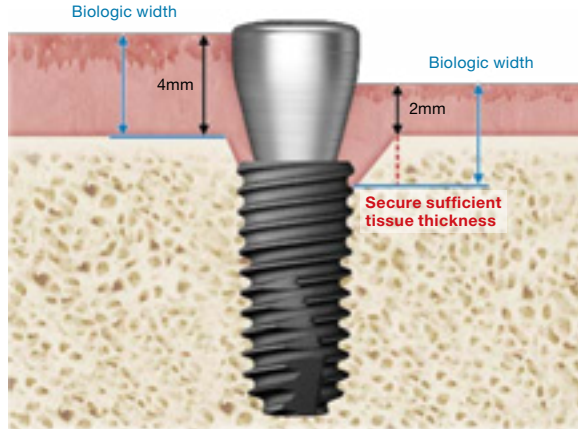

When the thickness of the peri-implant mucosa decreases, maintain the mucosal dimension by inducing a resorption of the upper alveolar bone to protect the underlying tissue.

- Implant placement depth taking prosthesis into consideration: The prosthetic plan after implant placement should be implemented in case of loading prosthesis in the wrong location, angle and depth of the implant. Therefore, there might be restriction in selecting type, material, shape of prosthesis.

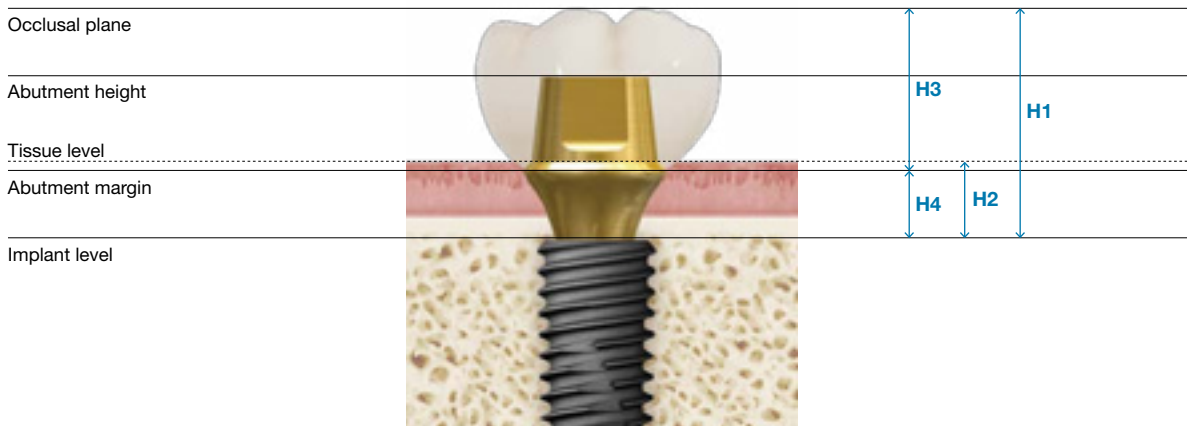

Implant Crown length [▶ Placement depth considering the prosthesis p.27](#)

**H1** Appropriate distance from implant level to occlusal plane: Posterior 9mm / Anterior 10mm

**H2** Distance from implant level to tissue level

**H3** Distance from the abutment margin to occlusal plane: Min. 6mm

**H4** Distance from implant level to abutment margin: Min. 3mm

## Common mistakes

- Common mistake in case the distance from the implant top to the antagonist tooth is less than 9mm. Thus, abutment with short G/H(2mm) can be used.

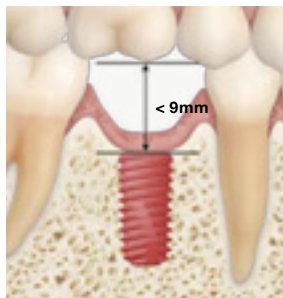

Implant is placed too shallow. distance from the implant top to the antagonist tooth is less than 9mm

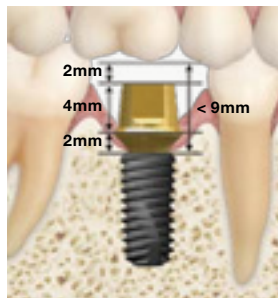

Abutment with low G/H specification used

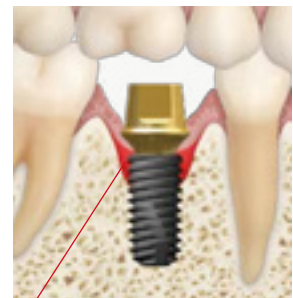

Bone resorption due to biologic width

## D KS Ø3.0/Ø3.5 implant precautions

- For a Ø3.0/Ø3.5 implant, G/H height is 0.5mm higher than a Ø4.0
- The thinner the implant diameter, the thinner the wall thickness.  
Raise hex seating by 0.5mm to compensate for strength.
- Required to use a product exclusively for Ø3.0/Ø3.5 implant: Lab analog, simple mount, cover screw

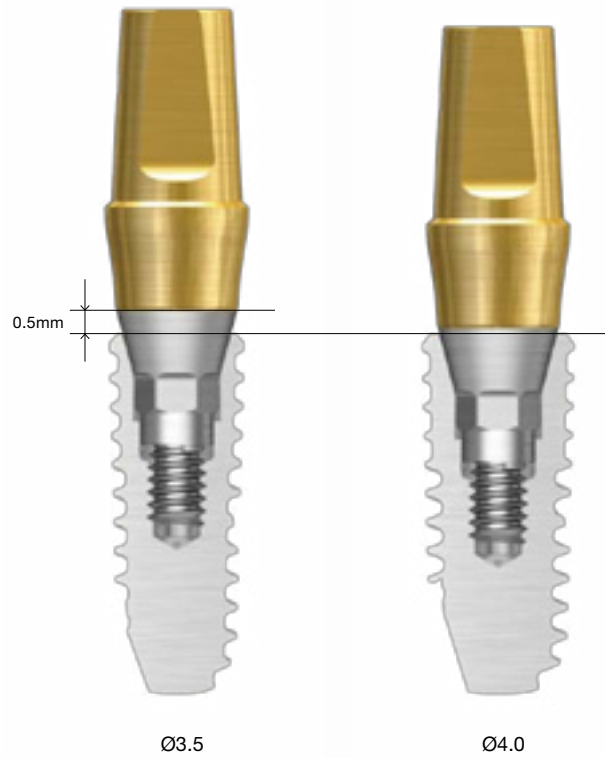

## 2 Mount

### A Adjust placement depth

- Guide for depth adjustment in 4mm flapless surgery
- Guide for additional placement in case of thin gingival height (2mm)
- Guide to help place 1mm below
- Hex positioning: Hex direction guide inside the implant

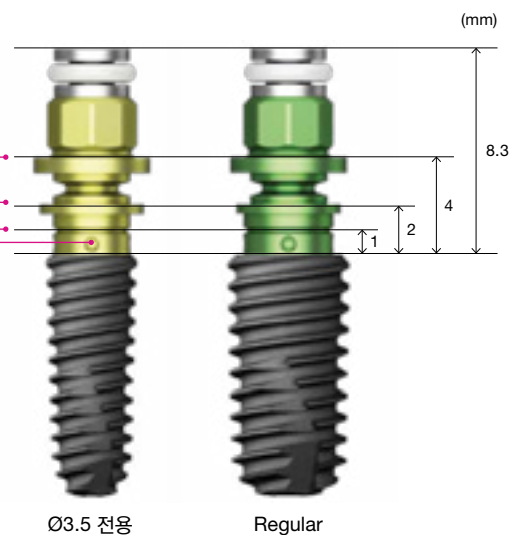

- In case of flapless surgery, place the implant with a 4mm guide

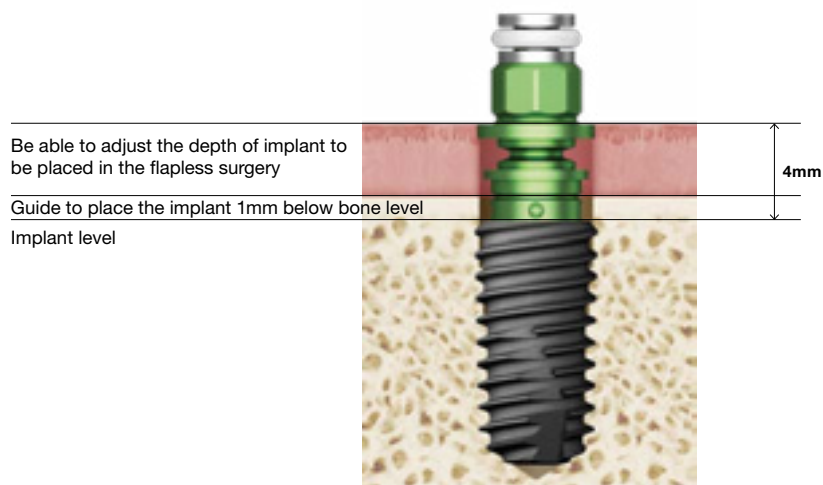

- In case of having lower gingival height, place the implant with 2mm below bone levelguide

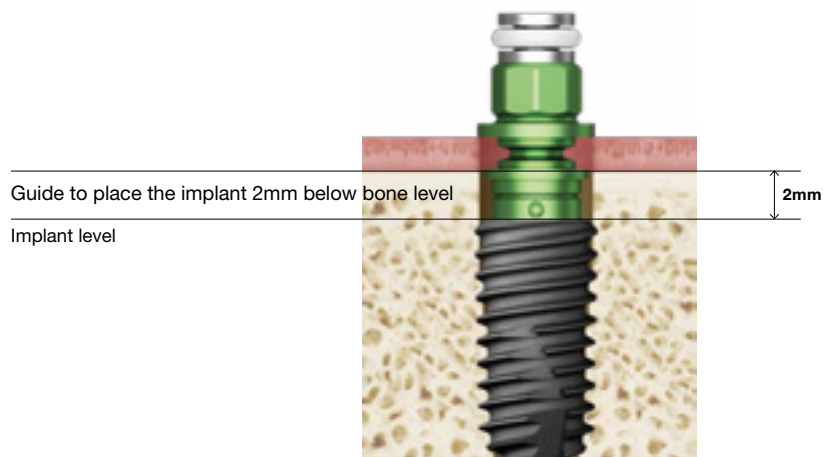

## B Check available space for the prosthesis

- Be able to check the expected prosthesis space taking the 8.3mm protruding part into consideration for the TS mount.

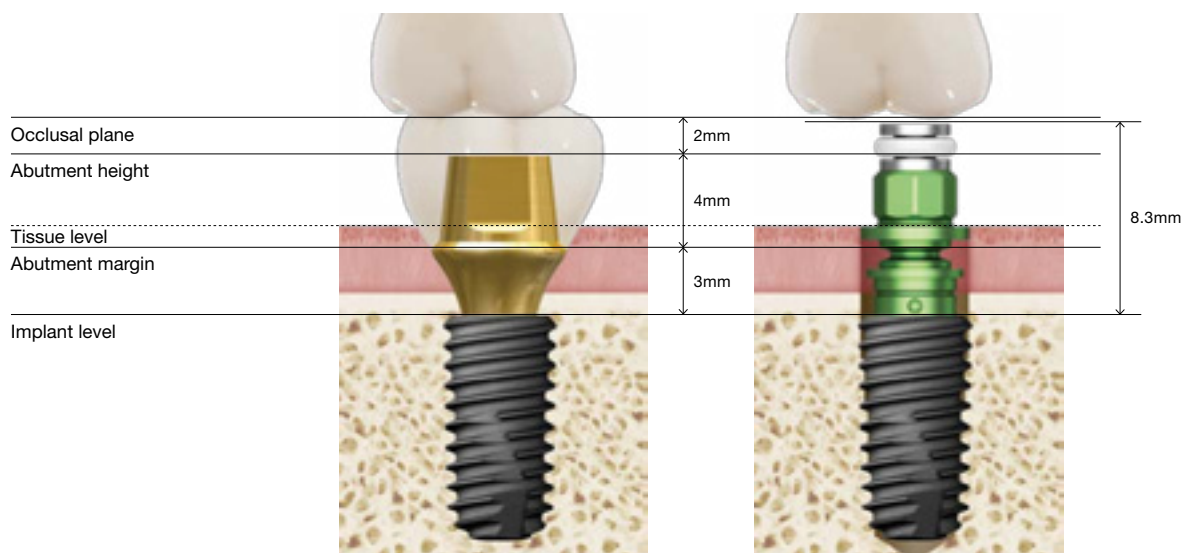

### C Check placement direction

- Easy to check the implant angle after placement.
- Check whether the mount angle is headed towards the central axis and interdental space of the natural antagonist teeth.



### D Prevent over-torque

- There is a protective component to prevent damage to the inside of the implant in case of torque overload (100Ncm).
- The mount body is broken but the screw is intact, so it can be easily removed with a 1.2 hex hand driver.

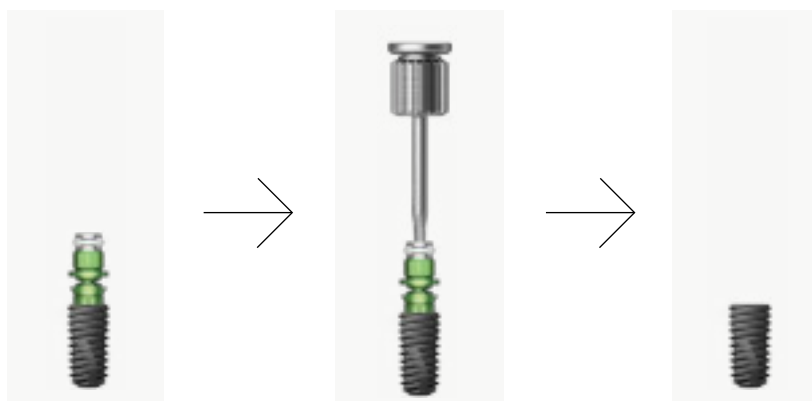
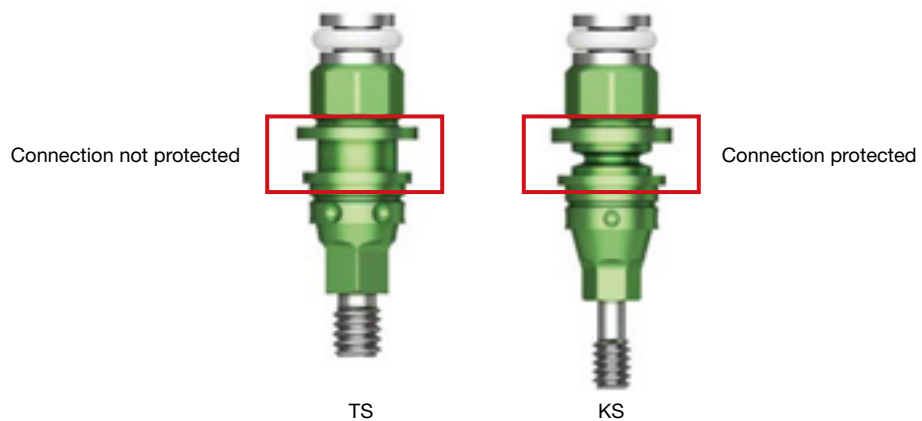

### 3 Cover screw

#### A Cover screw applications

- In a 2 stage surgery, the cover screw protects the internal structure of the implant in osseointegration period after implant placement.

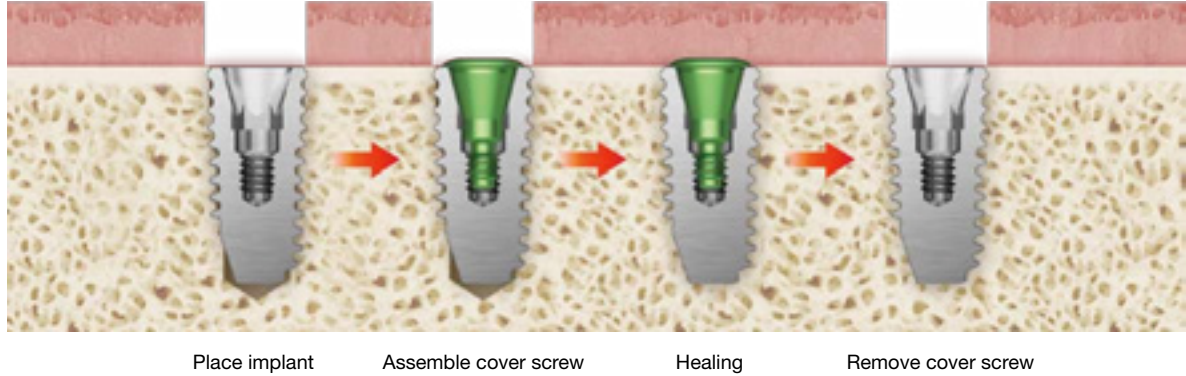

#### B How to select the correct specification

##### Step 1. Select platform

- Check whether the placed implant is a Ø3.5 specification or regular specification.
- Select the cover screw of the same platform as the installed implant.

Ø3.5사양 cover screw

Regular cover screw



Ø3.5사양 platform Implant

Regular platform Implant

##### Step 2. Select height

- Use cover screw with an appropriate height depending on the placement depth of the implant.
- The cover screw's concave part should be seated higher than the bone level.

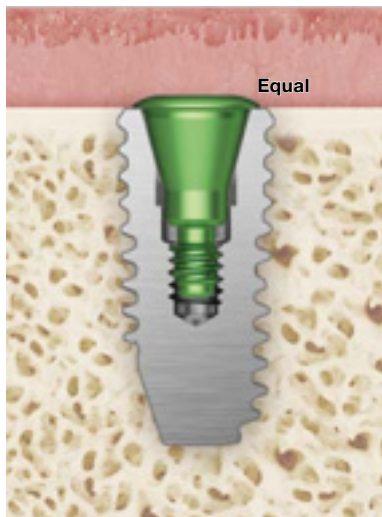

**Equal case:**  
Short(H: 0.4mm)

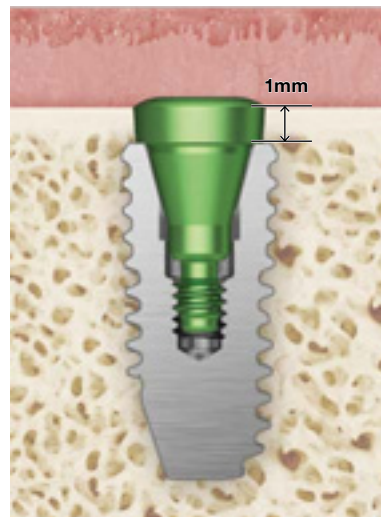

**Equal-1mm case:**  
Middle(H: 1.4mm)

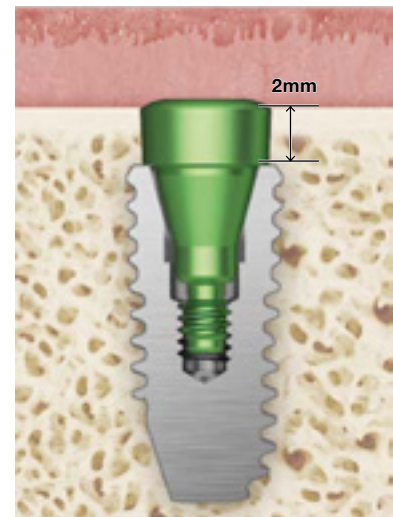

**1mm~ case:**  
Long(H: 2.0mm)

## 4 Healing abutment

### A Healing abutment applications

- In a 1-stage/2-stage surgery, the healing abutment promotes the healing of soft tissues and generate a transition zone to form the place where the prosthesis will be loaded
- Transition zone: Space between the implant top and gingival line

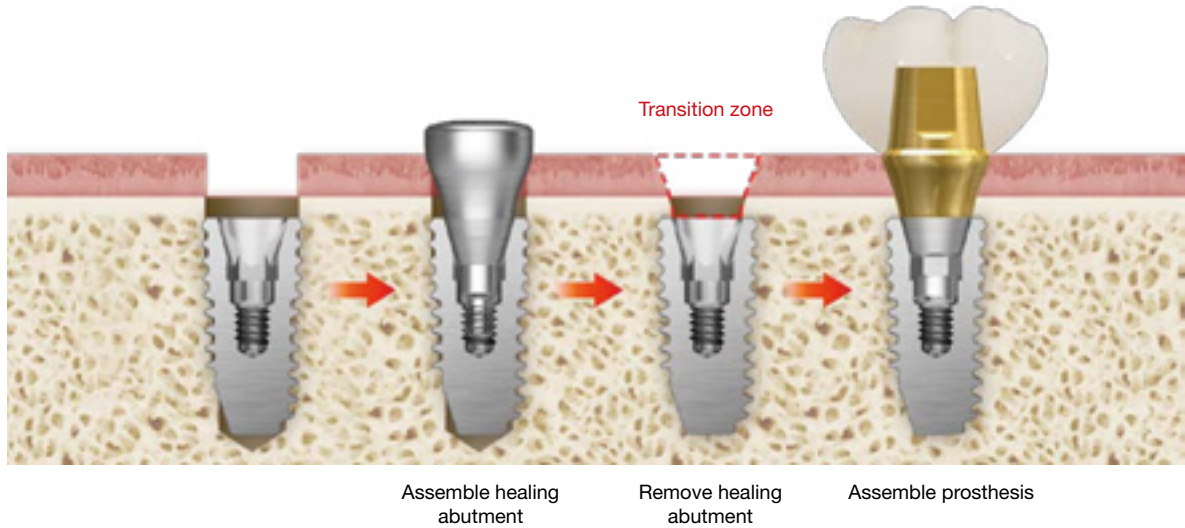

### B How to select the healing abutment specification

#### Step 1. Select diameter

- A healing abutment of the same diameter as the prosthetic abutment and similar to the average cervical size for each tooth position should be selected and used.
- Choose a diameter that will form an appropriate emergence profile for the prosthesis.

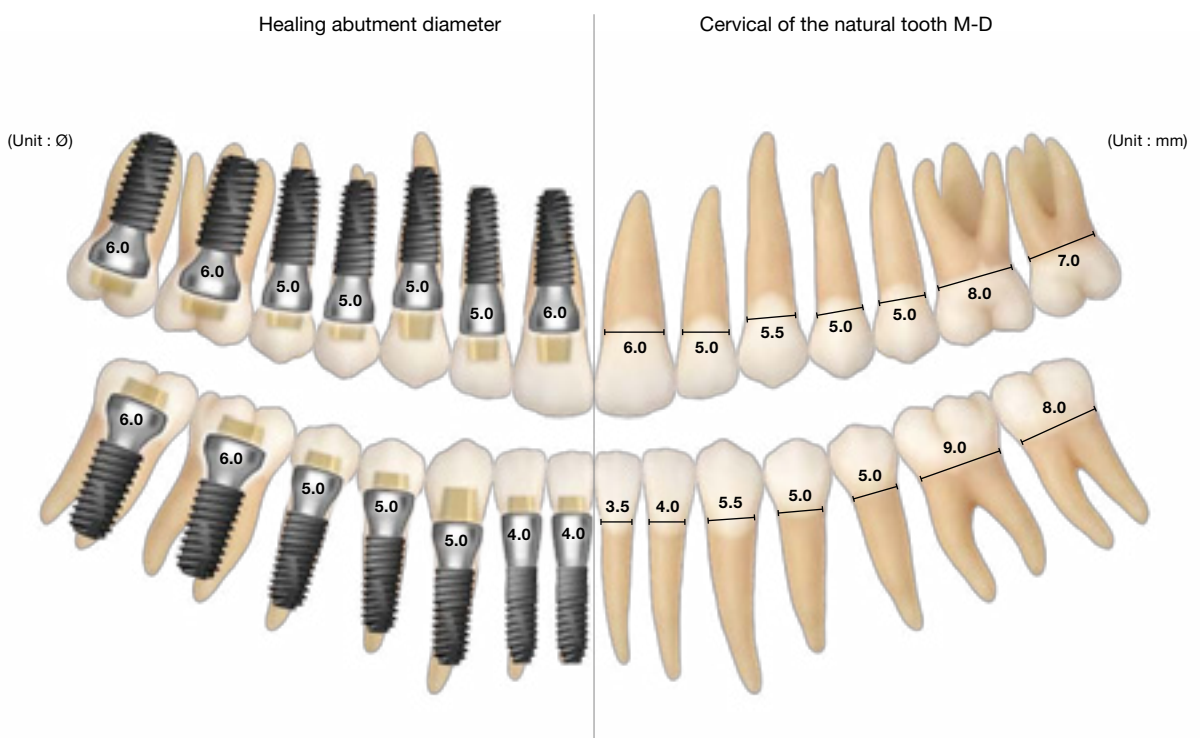

## Step 2. Select height

- If the healing abutment is covered with the gingiva, a transition zone cannot be formed, so select it 1~2mm higher than the thickness of the gingiva.

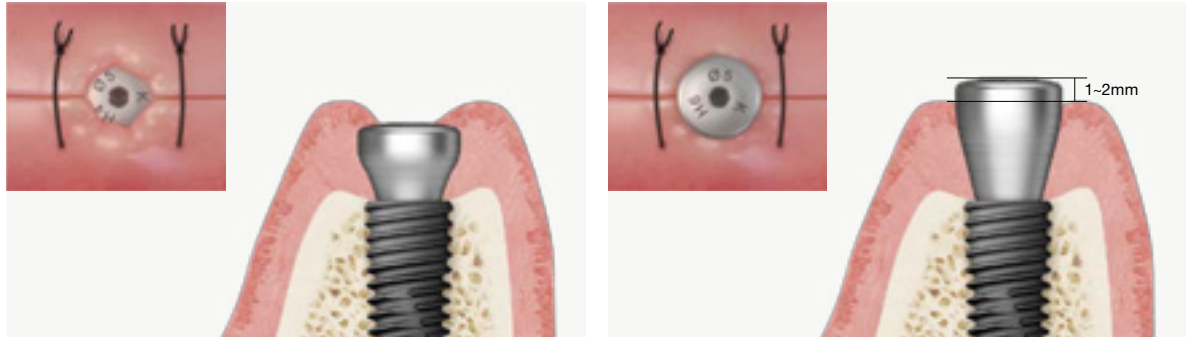

- Considering the G/H of the prosthetic abutment, select the height of the healing abutment.

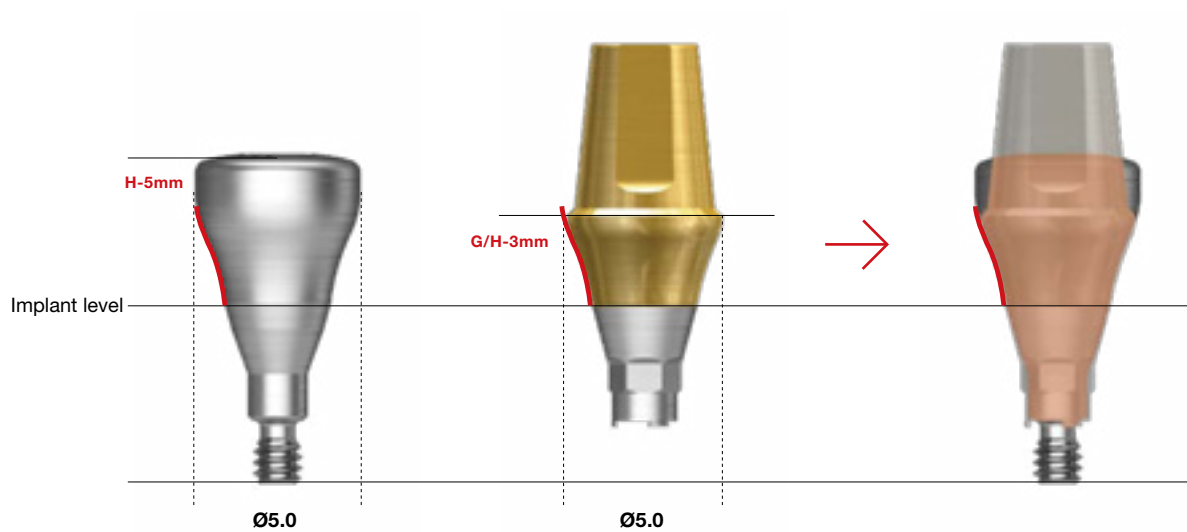

# Important Information and Legal Notices 2026.03 ver.1.1

## 1. IMPORTANT NOTICE

This catalogue is intended solely as an informational and educational guide for trained dental professionals. It does not replace the applicable Instructions for Use (IFU), product labelling, formal clinical training, treatment planning, or independent professional judgment.

All clinical protocols, drilling sequences, cleaning instructions, sterilization requirements, torque recommendations, indications, contraindications, warnings, and procedural steps must be verified against the current product-specific IFU and the applicable product label for the relevant REF/product code prior to use.

In the event of any discrepancy between this catalogue and the applicable IFU, product labelling, or other official Osstem documentation, the IFU, labelling, and official product documentation shall prevail.

## 2. PRODUCT INFORMATION, CHANGES, AND AVAILABILITY

All products, specifications, protocols, recommendations, illustrations, and other information contained in this catalogue are subject to change without prior notice.

Not all products may be approved, cleared, released, licensed, or otherwise available in all markets. Product availability, indications, and regulatory status may vary by country. For information on the current product portfolio, approved indications, and local availability, please contact your local Osstem representative or Customer Service and consult the current official Osstem documentation.

## 3. PROFESSIONAL USE ONLY

Osstem Implant products are intended for use by appropriately trained dental professionals only. Dental implant treatment involves complex professional procedures and requires appropriate education, clinical training, patient selection, treatment planning, and radiographic as well as clinical evaluation.

The suitability of any procedure must be assessed individually for each patient, taking into account anatomy, bone quality and quantity, occlusion, systemic conditions, oral hygiene, compliance, and any other relevant clinical factors.

## 4. PRODUCT DESCRIPTION AND COMPATIBILITY

Osstem Implant offers implant fixtures, prosthetic components, surgical instruments, and related materials for dental implant treatment. Product codes, specifications, lot numbers, dates of manufacture, and expiration dates, where applicable, must be checked on the product label before use.

Unless expressly stated otherwise in the applicable product documentation, Osstem Implant abutments, prosthetic components, instruments, and related accessories are intended to be used only with compatible Osstem Implant fixtures and components. Use in combination with components or instruments from other manufacturers may result in improper fit, incomplete locking, loosening, fracture, reduced performance, or other clinical complications.

## 5. STERILITY, CLEANING, REPROCESSING, AND STORAGE

Sterile products supplied in sterile packaging must be used only if the packaging is intact and the expiration date has not passed. If sterile packaging has been opened, damaged, or has expired, the product must not be used.

Single-use products must not be reused, reprocessed, or resterilized.

Reusable instruments must be cleaned, disinfected, inspected, maintained, and sterilized strictly in accordance with the applicable Osstem IFU before reuse.

Products must be stored in accordance with the applicable labelled storage conditions and protected from moisture, contamination, direct sunlight, and other adverse environmental conditions.

## 6. CLINICAL PROTOCOLS AND PROCEDURAL GUIDANCE

Any surgical, prosthetic, drilling, insertion, loading, cleaning, maintenance, or other procedural guidance shown in this catalogue is provided for general informational purposes only and must be adapted to the individual patient, the specific product, and the current approved IFU.

Clinicians remain solely responsible for selecting the appropriate treatment protocol and for determining whether the intended procedure, component selection, loading protocol, and clinical application are appropriate for the individual case and within the approved indications for the relevant product.

## 7. WARNINGS, CONTRAINDICATIONS, AND POSSIBLE COMPLICATIONS

Improper patient selection, inadequate treatment planning, non-compliance with the applicable IFU, improper use, off-label use, product modification, poor oral hygiene, infection, insufficient bone quality or quantity, excessive occlusal loading, or other unfavorable clinical conditions may result in complications or treatment failure.

Possible complications and adverse events may include, without limitation, implant instability or failure, loosening, fracture, bone loss, infection, soft- or hard-tissue complications, prosthetic complications, delayed healing, or the need for revision or removal.

Contraindications and precautions must always be assessed in accordance with the applicable Osstem product documentation and accepted professional standards of care.

## 8. INTENDED PURPOSE

The OSSTEM Implant System is an artificial dental root that has been designed for use in dental implant treatment in order to recover lost teeth. The system is implanted via a surgical method in maxillary or mandibular bone to replace natural dental root. The OSSTEM Implant System is indicated for use in partially or fully edentulous mandibles and maxillae, in support of single or multiple-units restorations including; cemented retained, screw retained, or overdenture restorations, and final or temporary abutment support for fixed bridgework. It is intended for delayed loading. Products with diameter of 3.3 mm or less must be used exclusively for mandibular anterior teeth in order to prevent fracture due to excessive occlusal load. The Ultra-Wide Implants are intended to be used only to replace molar teeth and angled abutments are not to be used with the Ultra-Wide Implants. Evaluate the quantity of bone and radiographs to assess any potential anatomical contraindications to use of the Ultra-Wide Implant. The applicable product-specific IFU must always be consulted to confirm the intended purpose, indications, limitations, and approved clinical applications of the relevant product.

## 9. ACCURACY OF INFORMATION

Although reasonable care has been taken in preparing this catalogue, typographical, editorial, translation, printing, and formatting errors may occur. Information may also become outdated as a result of product updates, regulatory changes, technical revisions, or clinical developments.

No representation is made that this catalogue is complete, current, or error-free in every respect. Users must verify all critical information against the current IFU, product labels, and other official Osstem documentation before clinical use.

## 10. ILLUSTRATIONS AND EXAMPLES

Product illustrations, diagrams, radiographic examples, case images, and step-by-step demonstrations are for illustrative purposes only. Unless expressly stated otherwise, they are not shown to scale and do not guarantee any clinical outcome.

Example cases do not constitute a promise or representation of treatment success in any individual case.

## 11. TRADEMARKS AND COMPANY NAMES

All trademarks, trade names, product names, brand names, and company names are the property of their respective owners.

# Important Contact Information



## International HQ

Osstem Implant Co., Ltd.  
3, Magokjungang 12-ro, Gangseo-gu  
Seoul 07801, Republic of Korea

☎ +82-2-2016-7000

☎ +82-2-2016-7001

🌐 [www.osstem.com](http://www.osstem.com)



## European HQ

Osstem Implant s.r.o.  
Radlická 740/113c  
158 00 Prague, Czech Republic

☎ +420-296-238-800

✉ [info@osstem.eu](mailto:info@osstem.eu)

🌐 [www.osstem.eu](http://www.osstem.eu)



## Hiossen HQ

Hiossen Implant Inc.  
85 Ben Fairless Drive, Fairless Hills  
PA 19030, USA

☎ +1-888-678-0001

✉ [master@hiossen.com](mailto:master@hiossen.com)

🌐 [www.hiossen.com](http://www.hiossen.com)



## Osstem Pharma HQ

Osstem Pharma Co., Ltd.  
123, Gasan digital 2-ro, Geumcheon-gu  
Seoul 08505, Republic of Korea

☎ +82-70-5118-0330

☎ +82-70-4369-1930

🌐 [www.osstempharma.com](http://www.osstempharma.com)



## Osstem Orthodontic HQ

OSSTEM Orthodontics Inc.  
13, Ojeongongeop-gil, Uiwang-si  
Gyeonggi-do 16072, Republic of Korea

☎ +82-31-477-9902

☎ +82-31-477-9904

🌐 [www.osstemortho.com](http://www.osstemortho.com)

## WE ARE GLOBAL

### Global Leader in Implant Dentistry

Driven by advanced technology and exceptional product quality, we are exporting to more than 90 countries.



## We are on Social Media



/osstem  
/osstem-europe  
/hiossen



/osstem  
/osstem.eu  
/hiossenimplants



/osstem  
/osstem\_europe  
/hiossen



/osstemglobal  
/@osstem\_europe  
/@hiossenimplants



**OSSTEM<sup>®</sup>**  
**IMPLANT**

© Osstem Implant Co., LTD. All rights reserved.

Osstem Implant<sup>®</sup> and/or other trademarks and logos of Osstem Implant<sup>®</sup> mentioned herein are trademarks or registered trademarks of Osstem Implant Co., Ltd. and/or its affiliates. For dental professionals only. Informations in this document are provided for general information purposes and do not constitute medical advice. Specifications, content and availability are subject to change without notice. Errors and omissions excepted.